

10 Watt WD Dual Series DC/DC Converters



Features

- Isolated Dual Outputs
- Universal 18 to 72 volt input range
- Up to 10 Watts of PCB Mounted Power
- Efficiencies to > 80%
- Fully Isolated, Filtered Design
- Low Noise Outputs
- Very low I/O Capacitance, 375 pF typical
- Water Washable Shielded Copper Case
- Five Year Warranty

Description

The universal input of the WD Dual series spans 18 to 72 volts. This makes these converters ideal for 24 and 48 volt battery, process control and telecom applications.

Coupled with these features is a low output noise of typically less than 80 mV peak to peak. The noise is also fully specified for RMS value and if even these impressive noise figures aren't enough, our applications section shows a simple add on circuit that can reduce the output noise to less than 10 mV p-p.

Full isolation is provided to help cut ground loops in industrial systems, where unknown input power quality could create havoc with sensitive, high precision analog circuitry.

No extra components or heatsinking are required for most applications saving you design time and valuable PCB space.

Selection Chart					
Model	Input Range VDC		Output		
	Min	Max	VDC	mA	Power W
*48D5.800WD	18	72	±5	±800	8
48D12.415WD	18	72	±12	±415	10
48D15.330WD	18	72	±15	±330	10

*Agency Approvals: CSA/UL 60950

What all this means to you is a tighter, more compact overall system that has the capability of being universally powered. Full application information is provided to make integrating this supply in your system a snap.

Other input and output voltage combinations may be factory ordered, contact CALEX applications engineering at 1-800-542-3355 for more information.

10 Watt Dual WD Series Block Diagram

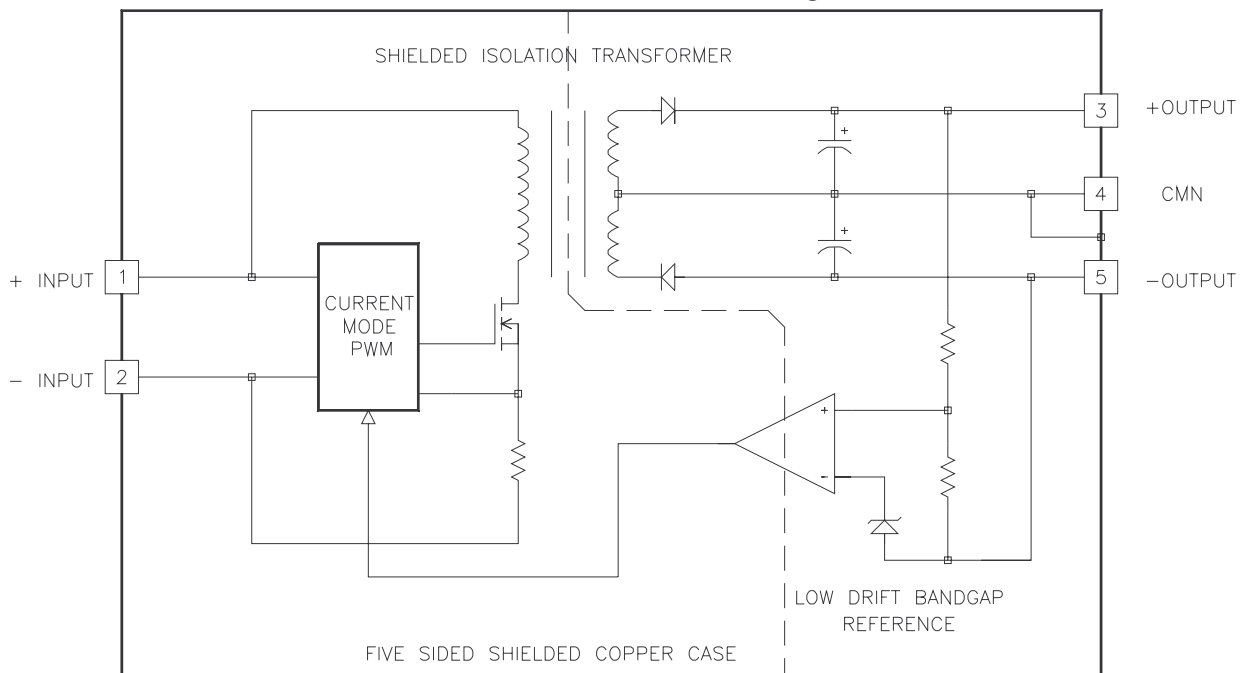

10 Watt WD Dual Series DC/DC Converters

Input Parameters*					
Model		48D5.800WD	48D12.415WD	48D15.330WD	Units
Voltage Range	MIN	18	18	18	VDC
	MAX	72	72	72	
Input Current	No Load	2	4	4	mA
	Full Load	210	265	260	
Efficiency	TYP	79	78	79	%
Switching Frequency	TYP	120			kHz
Maximum Input Overvoltage, 100ms Maximum	MAX	85			VDC
Turn-on Time, 1% Output Error	TYP	10			ms
Recommended Fuse		(2)			AMPS

Output Parameters*					
Model		48D5.800WD	48D12.415WD	48D15.330WD	Units
Output Voltage		±5	±12	±15	VDC
Output Voltage Accuracy	MIN	±4.950	±11.900	±14.900	VDC
	TYP	±5.000	±12.000	±15.000	
	MAX	±5.050	±12.100	±15.100	
Rated Load Range (3)	MIN	0	0	0	mA
	MAX	±800	±415	±330	
Load Regulation: 25% Max Load to Max Load (4)	TYP	0.3	0.2	0.2	%
	MAX	1.0	1.0	1.0	
Cross Regulation (5)	TYP	3	1	1	%
Line Regulation Vin = 18 - 72 VDC	TYP	0.3	0.1	0.1	%
	MAX	0.75	0.5	0.5	
Short Term Stability (6)	TYP	< 0.01			%/24Hrs
Long Term Stability	TYP	< 0.1			%/kHrs
Noise, Peak - Peak (1)	TYP	110	80	80	mV P-P
RMS Noise	TYP	30	20	20	mV RMS
Temperature Coefficient	TYP	50			ppm/°C
	MAX	250			
Short Circuit Protection		Short Term Current Limit			

NOTES

- * **All parameters measured at Tc = 25°C, nominal input voltage and full rated load unless otherwise noted. Refer to the CALEX Application Notes for the definition of terms, measurement circuits and other information.**
- (1) Noise is measured per CALEX application notes. Measurement bandwidth is 0-20 MHz. RMS noise is measured over a 0.01-1 MHz bandwidth. To simulate standard PCB decoupling practices, output noise is measured with a 10µF tantalum and 0.01µF ceramic capacitor located 1 inch away from the converter. Input ripple is measured into a 10µH source impedance.
 - (2) See our application note for picking the correct fuse size.
 - (3) The converter may be safely operated at any load from zero to the full rating. Dynamic response of the converter may degrade if the converter is operated with less than 25% output load.
 - (4) Load regulation is defined for loading/unloading both outputs simultaneously. Load range is 25 to 100%.
 - (5) Cross regulation is defined for loading/unloading one output while the other output is kept at full load. Load range is 25 to 100%.
 - (6) Short term stability is specified after a 30 minute warmup at full load, constant line and recording the drift over a 24 hour period.
 - (7) Case is tied to the CMN output pin.
 - (8) The functional temperature range is intended to give an additional data point for use in evaluating this power supply. At the low functional temperature the power supply will function with no side effects, however sustained operation at the high functional temperature may reduce the expected operational life. The data sheet specifications are not guaranteed over the functional temperature range.
 - (9) The case thermal impedance is specified as the case temperature rise over ambient per package watt dissipated.
 - (10) Specifications subject to change without notice.
 - (11) Water Washability - Calex DC/DC converters are designed to withstand most solder/wash processes. Careful attention should be used when assessing the applicability in your specific manufacturing process. Converters are not hermetically sealed.

10 Watt WD Dual Series DC/DC Converters

General Specifications*			
All Models			Units
Isolation (7)			
Isolation Voltage Input to Output 10 μ A Leakage	MIN	1544	VDC
Input to Output Capacitance	TYP	375	pF
Environmental			
Case Operating Range	MIN MAX	-40 85	$^{\circ}$ C
Case Functional Range (8)	MIN MAX	-50 100	$^{\circ}$ C
Storage Range	MIN MAX	-55 105	$^{\circ}$ C
Thermal Impedance (9)	TYP	16	$^{\circ}$ C/Watt
General			
Unit Weight	TYP	1.2	oz
Chassis Mounting Kits		MS6, MS8, MS15	

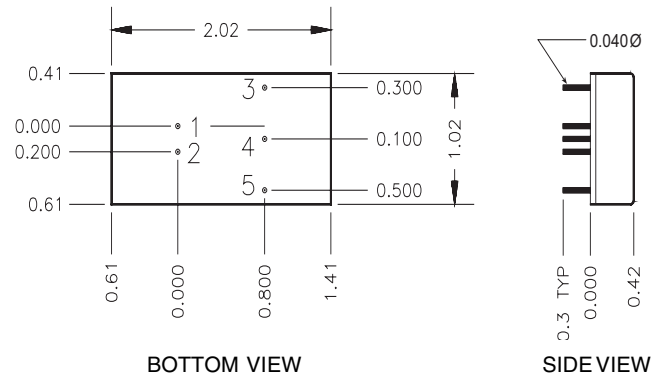

Mechanical tolerances unless otherwise noted:

X.XX dimensions: ± 0.020 inches

X.XXX dimensions: ± 0.005 inches

Pin location shown is for the mating PCB

Pin	Function
1	+INPUT
2	-INPUT
3	+OUTPUT
4	CMN
5	-OUTPUT

Applications Information

You truly get what you pay for in a CALEX converter, a complete system oriented and specified DC/DC converter - no surprises, no external noise reduction circuits needed, no heatsinking problems, just "plug and play".

The WD Dual series like all CALEX converters carries the full 5 year CALEX no hassle warranty. We can offer a five year warranty where others can't because with CALEX it's rarely needed.

Keep reading, you'll find out why.

General Information

The universal 18 to 72 volt input allows you to specify your system for operation from any 24 or 48 volt nominal input.

Five sided shielding is standard along with specified operation over the full industrial temperature range of -40 to $+85^{\circ}$ C case temperature.

Applying The Input

Figure 1 shows the recommended input connections for the WD Dual DC/DC converter. A fuse is recommended to protect the input circuit and should not be omitted. The fuse serves to prevent unlimited current from flowing in the case of a catastrophic system failure.

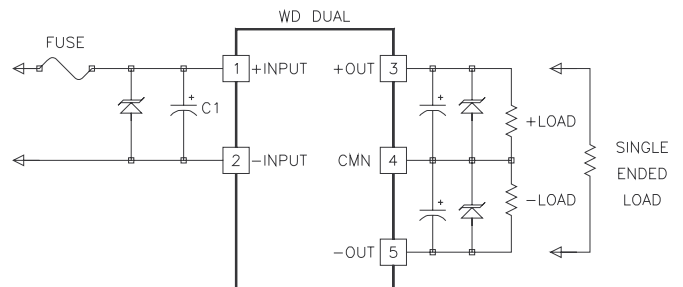

Figure 1.

If the source impedance driving the WD Converter is more than about 0.3 ohms at 120 kHz the optional capacitor C1 may be required (See text for more information). Optional transient protector diodes may be used if desired for added input and output protection. The output can be used as a 10, 24 or 30 V single output as shown.

10 Watt WD Dual Series DC/DC Converters

When using the WD Dual be sure that the impedance at the input to the converter is less than 0.3 ohms from DC to about 120 kHz, this is usually not a problem in battery powered systems when the converter is connected directly to the battery. If the converter is located more than about 1 inch from the input source an added capacitor may be required directly at the input pins for proper operation.

The maximum permissible source impedance is a function of output power and line voltage. The impedance can be higher when operating at less than full power. The minimum impedance is required when operating with a 18 volt input at full load. In general you should keep the voltage measured across the input pins less than 0.5 volts peak to peak (not including the high frequency spikes) for maximum converter performance.

There is no lower limit on the allowed source impedance, it can be any physically realizable value, even approaching 0.

If the source impedance is too large in your system you should choose an external input capacitor as detailed below.

Picking An External Input Capacitor

If an input capacitor is needed at the input to the converter it must be sized correctly for proper converter operation. The curve "RMS Input Current Vs Line Input" shows the RMS ripple current that the input capacitor must withstand with varying loading conditions and input voltages.

Several system tradeoffs must be made for each particular system application to correctly size the input capacitor.

The probable result of undersizing the capacitor is increased self heating, shortening it's life. Oversizing the capacitor can have a negative effect on your products cost and size, although this kind of overdesign does not result in shorter life of any components.

There is no one optimum value for the input capacitor. The size and capacity depend on the following factors:

- 1) Expected ambient temperature and your temperature derating guidelines.
- 2) Your ripple current derating guidelines.
- 3) The maximum anticipated load on the converter.
- 4) The input operating voltage, both nominal and excursions.
- 5) The statistical probability that your system will spend a significant time at any worst case extreme.

Factors 1 and 2 depend on your system design guidelines. These can range from 50 to 100% of the manufacturers listed maximum rating, although the usual derating factor applied is about 70%. 70% derating means if the manufacturer rated the capacitor at 1 A RMS you would not use it over 0.7 A RMS in your circuit.

Factors 3 and 4 realistically determine the worst case ripple current rating required for the capacitor along with the RMS ripple current curve.

Factor 5 is not easy to quantify. At CALEX we can make no assumptions about a customers system so we leave to you

the decision of how you define how big is big enough.

Suitable capacitors for use at the input of the converter are given at the end of this section.

Very Low Noise Input Circuit

Figure 2 shows a very low noise input circuit that may be used with the converters. This circuit will reduce the input reflected ripple current to less than 10 mA peak-peak ($V_{in} = 48 V$, 10 kHz to 1 MHz bw). See the discussion above for the optimum selection of C1.

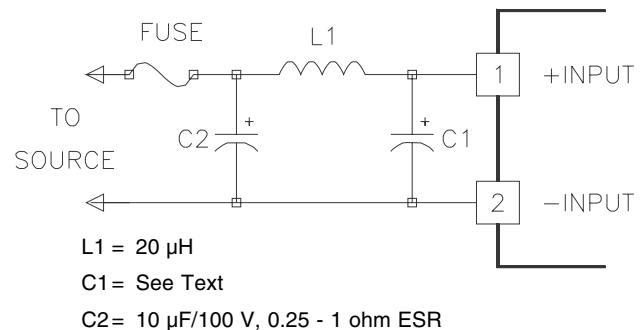

Figure 2.

This circuit will reduce the input reflected ripple current to less than 10 mA peak to peak. See the discussion in the text for help on the optimum selection of C1. L1 should be sized to handle the maximum input current at your lowest operating voltage and maximum expected output power.

Suggested Capacitor Sources

These capacitors may be used to lower your sources input impedance at the input of the converter. These capacitors will work for 100% load, worst case input voltage and ambient temperature extremes. They however, may be oversized for your exact usage, see "Picking An External Input Capacitor" above for more information. You may also use several smaller capacitors in parallel to achieve the same ripple current rating. This may save space in some systems.

Suitable capacitors can be found from the following sources:

United Chemi-Con SXE, RXC, RZ and RZA series
Suggested Part: SXE100VB33RM10X15LL
33 μF , 100V, 105° C RATED
ESR=0.3 OHMS
Allowable Ripple at 85°C = 0.8A

Nichicon PR and PF series
Suggested Part: UPR2A100MHH
100 μF , 100V, 105°C RATED
ESR=0.18 OHMS
Allowable Ripple at 85°C = 0.8A

Panasonic TS-NH Series
Suggested Part: ECES2AG331D
330 μF , 100V, 105°C RATED
ESR=0.2 OHMS
Allowable Ripple at 85°C = 1.1A

10 Watt WD Dual Series DC/DC Converters

Applying The Output

Figure 1 shows typical output connections for the WD Dual. In most applications no external output capacitance will be necessary. Only your normal 1 to 10 μ F tantalum and 0.001 to 0.1 μ F ceramic bypass capacitors sprinkled around your circuit as needed locally are required. Do not add extra output capacitance and cost to your circuit “Just Because”.

If you feel you must add external output capacitance, do not use the lowest ESR, biggest value capacitor that you can find! This can only lead to reduced system performance or oscillation. See our application note “Understanding Output Impedance For Optimum Decoupling” for more information and by all means use our low noise circuit provided.

Single Ended 10, 24 or 30 V Outputs

The dual outputs may also be used in a single ended mode as shown in figure 1 to get 10, 24 or 30 volts of output at the full rated power levels. To use the single ended mode just connect your load to the + and - Output pins and leave the CMN pin floating.

Ultra Low Noise Output Circuit

The circuit shown in figure 3 can be used to reduce the output noise to below 10 mV p-p over a 20 MHz bandwidth. Size inductor L1 appropriately for the maximum expected load current. All of the ground connections must be as short as possible back to the CMN pin. The filter should be placed as close to the WD Dual as possible, even if your load is at some distance from the converter.

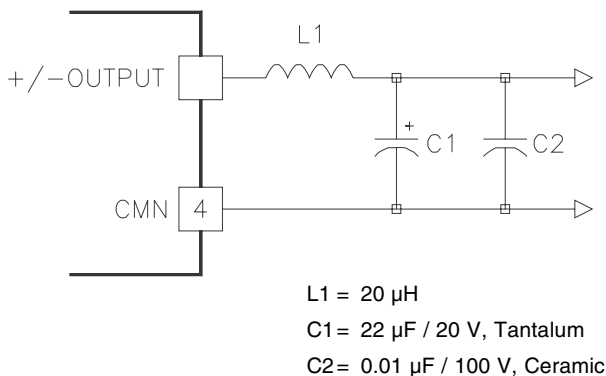

Figure 3.

This circuit can reduce the output noise to below 10 mV p-p over a 20 MHz bandwidth. Size inductor L1 appropriately for the maximum expected load current. The filter should be constructed as close as possible to the converter and all of the ground connections must be as short as possible back to the CMN pin.

Operation With Very Light Loads

Dynamic response and cross regulation of the WD Dual will degrade when the unit is operated with less than about 25% of full rated power. If this is a problem the most lightly loaded output may be “Pre-Loaded” with a resistor to common as needed. The exact amount of preloading required is dependent on your system requirements, so some experimentation is necessary to arrive at the optimum value.

Grounding

The input and output sections are fully floating from each other. They may be operated fully floating or with a common ground. If the input and output sections are connected either directly at the converter or at some remote location from the converter it is suggested that a 1 to 10 μ F, 0.5 to 5 ohm ESR capacitor bypass be used directly at the converters output pins. These capacitors prevent any common mode switching currents from showing up at the converters output as normal mode output noise. See “Applying the Output” for more information on selecting output capacitors.

Also see the CALEX application note “Dealing With Common Mode Noise” for more information on using common grounds.

Case Grounding

The copper case serves not only as a heat sink but also as a EMI shield. The 0.017 inch thick case provides >20 dB of absorption loss to both electric and magnetic fields at 120 kHz, while at the same time providing 20 to 40 % better heat sinking over competitive thin steel, aluminum or plastic designs.

The case shield is tied to the CMN output pin. This connection is shown on the block diagram. The case is floating from the input sections. The input is coupled to the outputs only by the low 375 pF of isolation capacitance. This low I/O capacitance insures that any AC common mode noise on the inputs is not coupled to your output circuits.

Compare this isolation to the more usual 1000 - 2000 pF found on competitive designs and you will see that CALEX provides the very best DC and AC isolation available. After all, you are buying an isolated DC/DC to cut ground loops. Don't let the isolation capacitance add them back in.

Temperature Derating

The WD Dual series can operate up to 85°C case temperature without derating. Case temperature may be roughly calculated from ambient by knowing that the case temperature rise is approximately 16°C per package watt dissipated.

For example: If a WD Dual converter is delivering 8 Watts with a 48 volt input, at what ambient could it expect to run with no moving air and no extra heatsinking?

Efficiency of the converter is approximately 80% at 8 watts of output power, this leads to an input power of about 10 Watts. The case temperature rise would be 10 - 8 Watts or 2 Watts x 16 = 32°C. This number is subtracted from the maximum case temperature of 85°C to get: 53°C.

This example calculation is for a WD Dual without any extra heat sinking or appreciable air flow. Both of these factors can greatly effect the maximum ambient temperature (see below). Exact efficiency depends on input line and load conditions, check the efficiency curves for exact information.

This is a rough approximation to the maximum ambient temperature. Because of the difficulty of defining ambient temperature and the possibility that the loads dissipation may actually increase the local ambient temperature significantly, these calculations should be verified by actual measurement before committing to a production design.

10 Watt WD Dual Series DC/DC Converters

Typical Performance ($T_c=25^\circ\text{C}$, $V_{in}=\text{Nom VDC}$, Rated Load).

