

# 30 Watt NT Single Series DC/DC Converters



## Description

These single output DC/DC converters are designed to provide a wide range of PCB mount power solutions. The wide 2:1 input voltage range covers the common American and European telecom standards.

For flexibility, a trim pin is included to adjust the output voltage. Use it to compensate for voltage drops in your system's wiring or to achieve non standard voltages. Use the remote ON/OFF function to maximize battery life.

The NT Single Series continues the CALEX tradition of reliable design by including transient overvoltage suppressor diode protection at the output terminals. Also provided as standard are overcurrent and overtemperature protection circuits. These features assure zero failure rate operation when using the NT Single Series. All CALEX products are backed by a 5 Year Warranty.

## Features

- Only 2.02" x 1.62" x 0.55" high
- -40° to +90°C case operating range standard
- Very low OFF current, 1 mA typically
- Transient overvoltage protected output
- Overcurrent and overtemperature protection
- Up to 86% efficiency
- 5 Year Warranty

Selection Chart				
Model	Input Range VDC		Output VDC	Output mA
	Min	Max		
*48S5.5000NT	36.0	72.0	5.0	5000
48S12.2500NT	36.0	72.0	12.0	2500
48S15.2000NT	36.0	72.0	15.0	2000

\*Agency Approvals: CSA/UL 60950

25 - 30 Watt NT Single Series Block Diagram

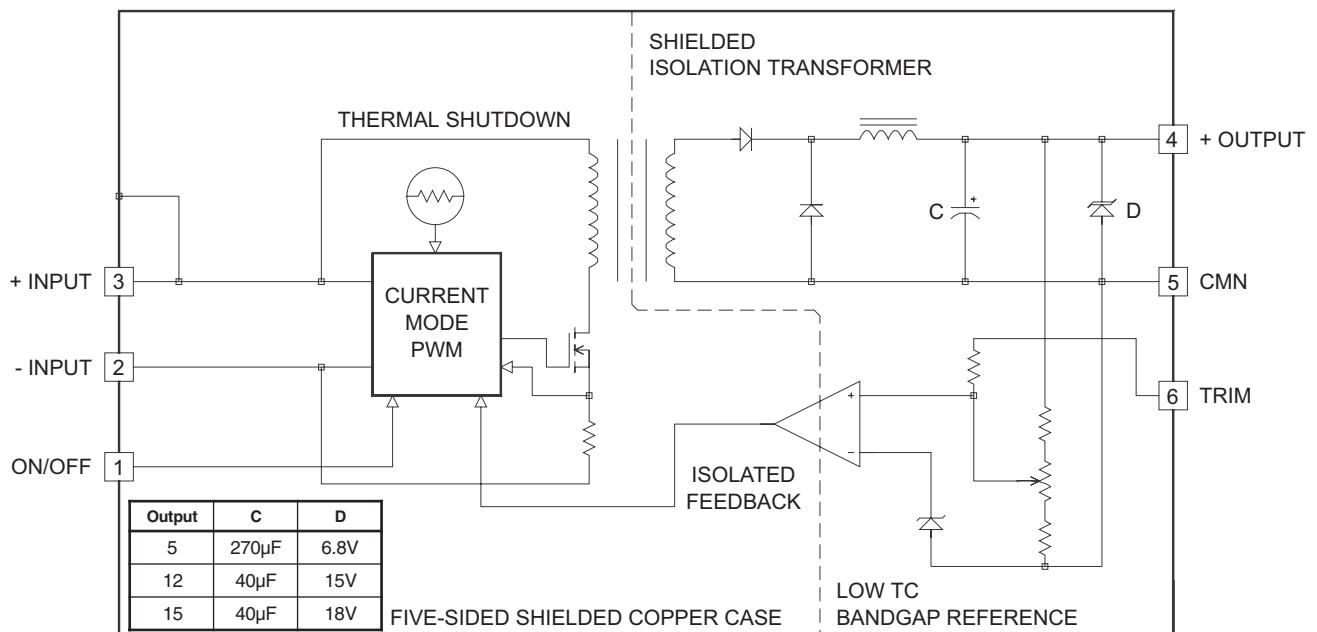

# 30 Watt NT Single Series DC/DC Converters

Input Parameters*					
Model		48S5.5000NT	48S12.2500NT	48S15.2000NT	Units
Voltage Range	MIN	36.0			VDC
	TYP	48.0			
	MAX	72.0			
Input Current Full Load	TYP	630	730	730	mA
	No Load	4	4	4	
Efficiency	TYP	84	86	86	%
Switching Frequency	TYP	200			kHz
Maximum Input Overvoltage, 100ms No Damage	MAX	85			VDC
Turn-on Time	TYP	10			ms
Recommended Fuse		(2)			

Output Parameters*					
Model		48S5.5000NT	48S12.2500NT	48S15.2000NT	Units
Output Voltage		5	12	15	VDC
Rated Load (3)	MIN	1250	625	500	mA
	MAX	5000	2500	2000	
Voltage Range 100% Load	MIN	4.950	11.900	14.900	VDC
	TYP	5.000	12.000	15.000	
	MAX	5.050	12.100	15.100	
Load Regulation Min-Max Full Load	TYP	0.5	0.2	0.2	%
	MAX	1.0	1.0	1.0	
Line Regulation Vin = Min-Max VDC	TYP	0.2			%
	MAX	1.0			
Short Term Stability (4)	TYP	<0.02			%
Long Term Stability	TYP	<0.05			%/kHrs
Transient Response (5)	TYP	125	200	200	µs
Dynamic Response (6)	TYP	80	300	300	mV peak
Input Ripple Rejection (7)	TYP	60			dB
Noise, 0-20MHz bw (8)	TYP	1% of output voltage			mV P-P
Temperature Coefficient	TYP	50			ppm/°C
	MAX	150			
Overvoltage Clamp	TYP	6.8	15	18	VDC
Short Circuit Protection to Common for all Outputs		Provides continuous protection with current limiting and thermal overload techniques			

## NOTES

- \* **All parameters measured at Tc=25 °C case temperature, nominal input voltage and full rated load unless otherwise noted. Refer to the CALEX Application Notes for definition of terms, measurement circuits and other information.**
- (2) See our application note on fusing DC/DC converters.
  - (3) Minimum load required for rated regulation only. Module will not be damaged if run at less than minimum load.
  - (4) Short term stability is specified after a 30 minute warm-up at full load, and with constant line, load and ambient conditions.
  - (5) The transient response is specified as the time required to settle from 50 to 75% step load change (rise time of step = 20µSec.) to a 1% error band.
  - (6) Dynamic response is the peak overshoot voltage during the transient response time defined in note 5.
  - (7) The input ripple rejection is specified for DC to 120Hz ripple with a modulation amplitude of 1% Vin.
  - (8) Noise is measured per CALEX Application Notes. Output noise is measured with a 0.01µF ceramic connected directly across the output pins.
  - (9) The ON/OFF pin is Open Collector TTL, CMOS, and relay compatible. The input to this pin is referenced to Pin 2, -Input and is protected to +100 VDC.
  - (10) Case is tied to Pin 3, +Input.
  - (11) Full output trim range may not be available at full load and minimum input voltage. Full trim is guaranteed from minimum input voltage +5% and full load.
  - (12) The case thermal impedance is specified as the case temperature rise over ambient per package watt dissipated.
  - (13) Specifications subject to change without notice.
  - (14) Water Washability - Calex DC/DC converters are designed to withstand most solder/wash processes. Careful attention should be used when assessing the applicability in your specific manufacturing process. Converters are not hermetically sealed.

# 30 Watt NT Single Series DC/DC Converters

General Specifications*			
All Models			Units
<b>ON/OFF Function (9)</b>			
ON Logic Level or Leave Pin Open	MIN	8.0	VDC
OFF Logic Level	MAX	2.0	VDC
Input Resistance	TYP	100	kohms
Converter Idle Current ON/OFF Pin Low	TYP	<1	mA
<b>Isolation</b>			
Isolation Voltage (10) 10µA Leakage Input-Output	MIN	1544	VDC
Input to Output Capacitance	TYP	300	pF
<b>Output Trim Function</b>			
Input Resistance	TYP	20	kohms
Programming Range (11)	MIN	±5	%
<b>Environmental</b>			
Case Operating Range No Derating	MIN	-40	°C
	MAX	+90	
Storage Range	MIN	-55	°C
	MAX	100	
Thermal Impedance (12)	TYP	10	°C/Watt
Thermal Shutdown Case Temperature	TYP	100	°C
<b>General</b>			
Unit Weight	TYP	1.9	oz
Chassis Mounting Kit		MS8	

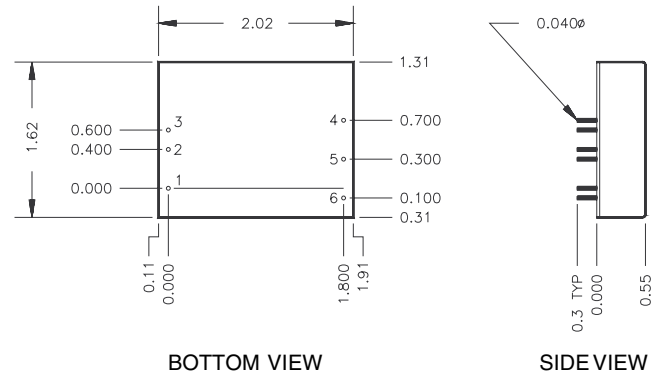

Mechanical tolerances unless otherwise noted:

X.XX dimensions: ±0.020 inches

X.XXX dimensions: ±0.005 inches

Seal around terminals is not hermetic. Do not immerse units in any liquid.

Pin	Function
1	ON/OFF
2	-INPUT
3	+INPUT
4	+OUTPUT
5	CMN
6	TRIM

## 25-30 Watt NT Single Typical Application

Figure 1 shows the recommended connections for the NT Singles. Capacitor C1 is required for proper operation (see below). The trim and ON/OFF pins can be safely left floating if they are not used. The input fuse should not be omitted.

The fuse prevents unlimited current from flowing in the case of a catastrophic system failure, and also protects the DC/DC converter input circuit.

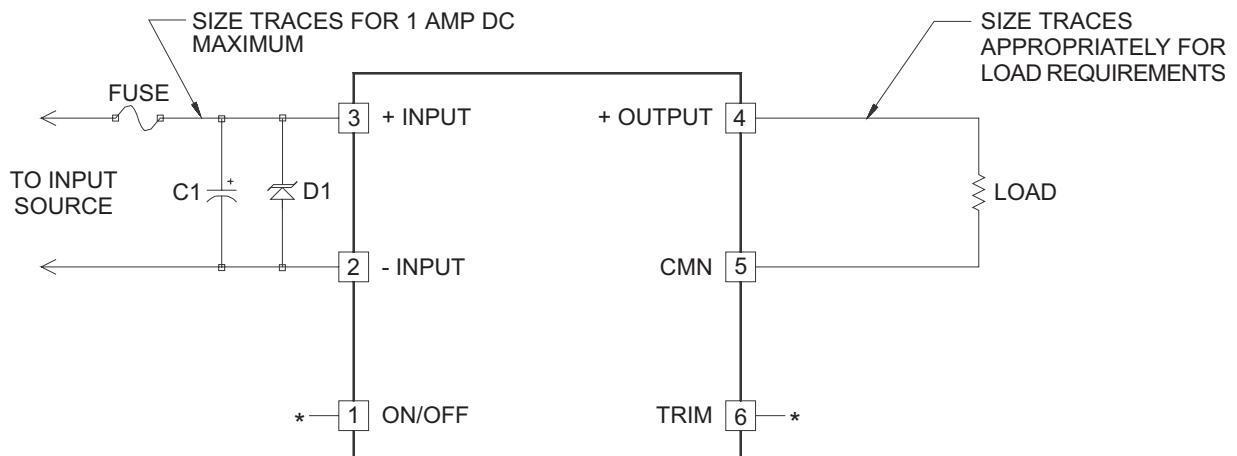

C1 - Is required for proper operation, see text  
 D1 - Overvoltage clamp is optional, see text

\* PINS 1 AND 6 MAY BE LEFT FLOATING IF NOT USED

Figure 1. Recommended application circuit for NT Single Series

# 30 Watt NT Single Series DC/DC Converters

## Sizing The Input Capacitor

For maximum reliability the NT Single Series must use a capacitor of sufficient ripple handling capability connected across the input pins. The probable result of undersizing (over stressing) this capacitor is increased self heating, shortening of the capacitors and hence shortening of your systems' life. Oversizing the capacitor can have a negative effect on your product's cost and size, although this kind of overdesign does not result in shorter life of any components. There is no one optimum value for this capacitor. The size and capacity are dependent on the following factors:

- 1) Expected ambient temperature and your temperature derating guidelines
- 2) Your ripple current derating guidelines
- 3) The maximum anticipated load on the converter
- 4) The minimum input voltage expected on the converter
- 5) The statistical probability that your system will spend a significant amount of time at any worst case extreme

Factors 1 and 2 are determined by your system design guidelines. These can range from 50% to 100% of the manufacturer's rated maximum, although a usual derating factor is 70% of manufacturer's maximum limit. 70% derating means that if the capacitor manufacturer says their capacitor can do 1 A RMS and 100 VDC you would not use the part over 700 mA RMS and 70 VDC. Surge voltage rating should also be evaluated against any expected voltage surges when selecting a capacitor working voltage.

Factors 3 and 4 realistically determine the worst case ripple current. The reflected ripple current increases with output load and increases as the input voltage decreases. So if you are running with a solid 48 VDC input and at 50% load your capacitors required ripple current rating would decrease by more than 2:1 from what would be required for operation at 36 VDC with full load (see the "Input Reflected Ripple" curve).

Factor 5 is not easy to quantify. At CALEX, we can make no assumptions about a customer's system so we design for continuous operation at worst case extremes.

## Example Of Capacitor Sizing

Given the following conditions, select the minimum size capacitor needed to provide reliable performance:

Converter .....	48S5.5000NT
Minimum Input Voltage .....	Voltage 40 VDC
Maximum Input Voltage .....	Voltage 52 VDC
Maximum Load .....	5 Amps
Maximum Ambient Temperature ....	40°C
Your Capacitor Voltage	
Derating Guideline .....	70% of Maximum Specification
Your Capacitor Current	
Derating Guideline .....	70% of Maximum Specification

## Solution

According to the NT Single Series "Reflected Input Ripple Vs. Line Input" curve at 40 VDC input and 5 Amps output (100% of rated load), the reflected input ripple can be read as 975 mA RMS. From the derating guidelines the capacitor's rated voltage and ripple current can be determined.

Capacitor voltage rating is calculated as:

$$V = \frac{1}{\text{Voltage Derating Factor}} \times \text{Maximum Expected Input}$$

$$V = \frac{1}{0.7} \times 52 = 74 \text{ Volts or greater}$$

$$I = \frac{1}{\text{Current Derating Factor}} \times \text{Reflected Ripple}$$

$$= \frac{1}{0.7} \times 975 \text{ mA} = 1.39 \text{ A RMS or greater at } 45^\circ\text{C}$$

(40° C ambient + 5° C for self heating)

A capacitor selection can now be made. Look only at controlled low ESR types (where the ESR is specified as a maximum) because these usually have the highest ripple current capability per unit volume.

Be careful to compare apples to apples. Some manufacturers specify their capacitors at 85°C and others specify at 105°C. The manufacturers give temperature derating guidelines so all capacitors should be normalized to your maximum ambient (plus 5°C to account for self heating) before making a selection. Since the NT Single Series operates at 200 kHz the frequency usually does not have to be derated since most modern low ESR capacitors are rated at 100 kHz or more.

One note: The temperature derating multipliers are based on the capacitor's expected life at 105°C. The life of a capacitor operating at a significantly lower temperature will not be greater if the ripple current in the part is increased over the 105°C rating. This means that a capacitor rated for 1 A RMS current at 105°C and 2 A RMS at 50°C will have the same life if used at either point while the same capacitor used at 1 A RMS and 50°C will have a longer life.

## Suggested Capacitor Sources

Suitable capacitors can be acquired from the following sources:

<b>United Chemi-Con</b>	SXE, RXC, RZ and RZA Series
Suggested Part:	SXE100VB221M12.5X35LL
	220µF, 100V, 105°C Rated
	ESR=0.087 Ohms
	Allowable Ripple=1.04 A @ 105°C
<b>Nichicon</b>	PR and PF
Suggested Part:	UPR100102MPHRH
	1000µF, 100V, 105°C Rated
	ESR=0.047 Ohms
	Allowable Ripple=1.32 A @ 105°C
<b>Panasonic</b>	HFE Series
Suggested Part:	ECEA2AFE221L
	220µF, 100V, 105°C Rated
	ESR=0.089 Ohms
	Allowable Ripple=1.04 A @ 105°C

# 30 Watt NT Single Series DC/DC Converters

The suggested capacitors will work for any line and load condition, however, they may be oversized for your application. High ripple current film capacitors may also be used and may provide longer life or smaller size.

## Low Noise Input Filtering Circuit

To reduce the input reflected ripple to less than 100 mA peak-to-peak the circuit shown in Figure 2 may be used. Use reasonable caution when selecting an inductor other than the one specified. Nearly any 105°C rated capacitor can be used for the 10µF / 100V part. To prevent input filter peaking the ESR should be in the range of 0.5 to 2 ohms. Do not use the lowest ESR capacitor available for this part. This will render the filter ineffective.

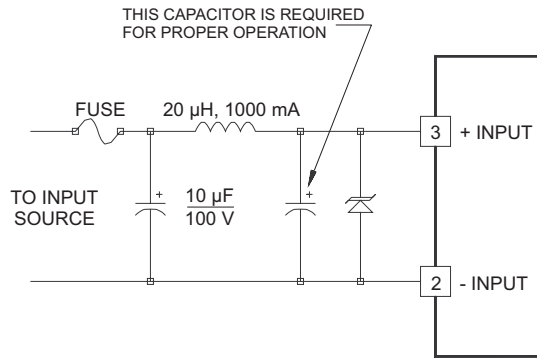

Figure 2. Low noise input filter circuit

## Input Overvoltage Protection

As shown in figure 1, optional transient overvoltage protection may be used at the input of the converter. This should be considered if your application circuit could present a voltage greater than the NT Series maximum transient voltage listed on the data sheet. This device could also serve as a reverse input voltage protector if used with a suitable fuse.

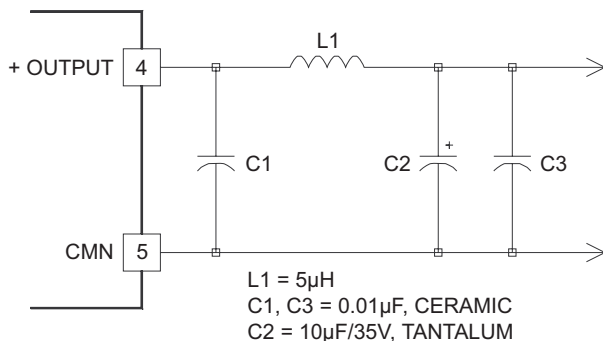

Figure 3. Low noise output filter circuit

## Low Noise Output Filtering Circuit

Extra output filtering is easy with the NT Series due to the high, constant 200 kHz switching frequency. The optional circuit shown in figure 3 can reduce the output noise to 15 mV p-p on a 5 Volt output converter and 40 mV p-p on 12 and 15 Volt output converters. The inductor should be sized appropriately for your maximum load current. No extra large capacitance is required on the output of the converter other than the components shown and the standard bypassing on your PCB. Large, low ESR capacitors on the output of the converter can actually make the output noise worse or cause oscillation.

See the CALEX application note on “Understanding Output Impedance” for more information.

## Remote ON/OFF Circuit Operation

The remote ON/OFF pin is best applied as follows:

To turn the unit off, the ON/OFF pin should be tied to the - Input pin. This is best done by an open collector arrangement or contact closure.

To turn the unit on, let the ON/OFF pin float.

If the remote ON/OFF pin is not used, it may be safely left floating. There is a 100K internal pull-up resistor inside the unit to +9 Volts DC.

Other applications of the ON/OFF function can be found in the application note, “Understanding the Remote ON/OFF Function”.

## Proper Application Of The Trim Pin

The trim pin is used to adjust the output voltage slightly to compensate for voltage drops in the system’s wiring. Figure 4 shows the proper application of the trim pin. Either a 10K trimpot or fixed resistors may be used.

Other applications for the TRIM function can be found in the CALEX application note, “Applying the Remote Sense and Trim Functions on DC/DC Converters.”

Use one resistor for either trim up or trim down. The values can range from infinity to zero ohms with zero ohms providing the most trim.

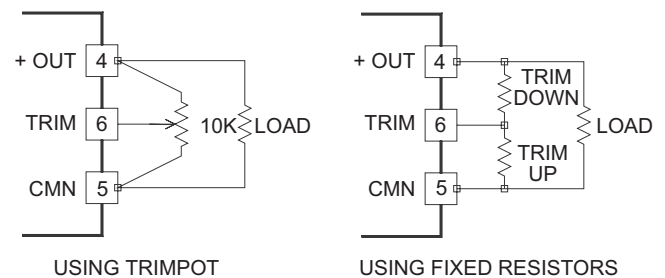

Figure 4. Output trim methods

# 30 Watt NT Single Series DC/DC Converters

## 5.2, 8.5 and 10 Volt Output Applications

The NT series can be adjusted easily for other non-standard output voltages. To get a 5.2 Volt output use a 5 Volt output converter and trim the output up to 5.2 Volts. To get either a 8.5, 9 or 10 Volt output use a 12 Volt output converter and trim the output down (12 Volt NT converters typically trim down to 8.5 Volts).

The output power must be limited to either 25 or 30 Watts when trimming the output up (the output current must be reduced to keep a constant power output). When trimming the output down, the output current must be kept at or below the maximum current listed for that model.

## Temperature Derating Guidelines

Care must be taken in the application of all power devices. Be sure to account for the self heating in your instrument due to the power converter and the loads. For minimum temperature gradient, the hottest components should be mounted at the bottom of your system (bottom of a vertical PCB) and the coolest components at the top of the system. This will help to even the temperature of the entire system and prevent temperature gradients.

The NT Single Series has a thermal impedance of 10°C per package Watt dissipated. During normal operation the NT Single Series can be expected to run at 86% efficiency at 48 VDC and full load. This means that the NT Single Series is dissipating nearly 5 Watts internally at full load. This, therefore, translates to a package temperature rise of 50°C (10°C/Watt x 5 Watts dissipated).

The maximum rated case temperature for the NT Series is 90°C. This means that, in the absence of other heat sources (including the load that the converter is powering) and with at least 3 inches of clearance, the NT Single Series can be expected to operate at full load in an ambient temperature of 40°C.

Additional heat sinks or cooling air flow can extend the ambient temperature of operation significantly.

In the event of system cooling blockage or failure, the thermal shut-off of the NT Single Series will prevent any catastrophic power converter failure. When the ambient temperature cools below the thermal limit temperature the NT Single Series will re-start.

Typical Performance (Tc=25°C, Vin=Nom VDC, Rated Load).

