

15 Watt XC Single Series DC/DC Converters

Features

- Extra Wide 3:1 Input Voltage Range (9-27, 24-72)
- Low Noise, Highly Regulated Single Outputs
- No Derating to 80°C Case Temperature
- Six-Sided Shielded Low Thermal Gradient Copper Case
- 500 VDC Minimum Input to Output Isolation
- Overvoltage Protected Input and Outputs
- Pulse by Pulse Digital Current Limiting
- Direct Output Parallel for More Power
- 5 Year Warranty

Description

These single output converters are designed for wide input range, low noise, telecommunications, medical, industrial and instrument applications. The extra wide input range (3:1) is ideal for battery or unregulated input applications.

These converters are state-of-the-art 70kHz MOSFET based designs that provide outstanding line and load regulation.

The single outputs are regulated with a high loop gain current mode control method that provides linear regulator type performance with a true, high efficiency switching DC/DC topology. The large amount of loop gain insures excellent input ripple rejection and line transient response.

A logic shutdown pin to control converter operation is included. The XC Single Series is protected from output shorts to common by a high speed, pulse by pulse digital, current limit circuit.

Selection Chart				
Model	Input Range VDC		Output VDC	Output mA
	MIN	MAX		
12S5.3000XC	9.0	27.0	5.0	3000
12S12.1250XC	9.0	27.0	12.0	1250
12S15.1000XC	9.0	27.0	15.0	1000
48S5.3000XC	24.0	72.0	5.0	3000
48S12.1250XC	24.0	72.0	12.0	1250
48S15.1000XC	24.0	72.0	15.0	1000

15 Watt XC Single Series Block Diagram

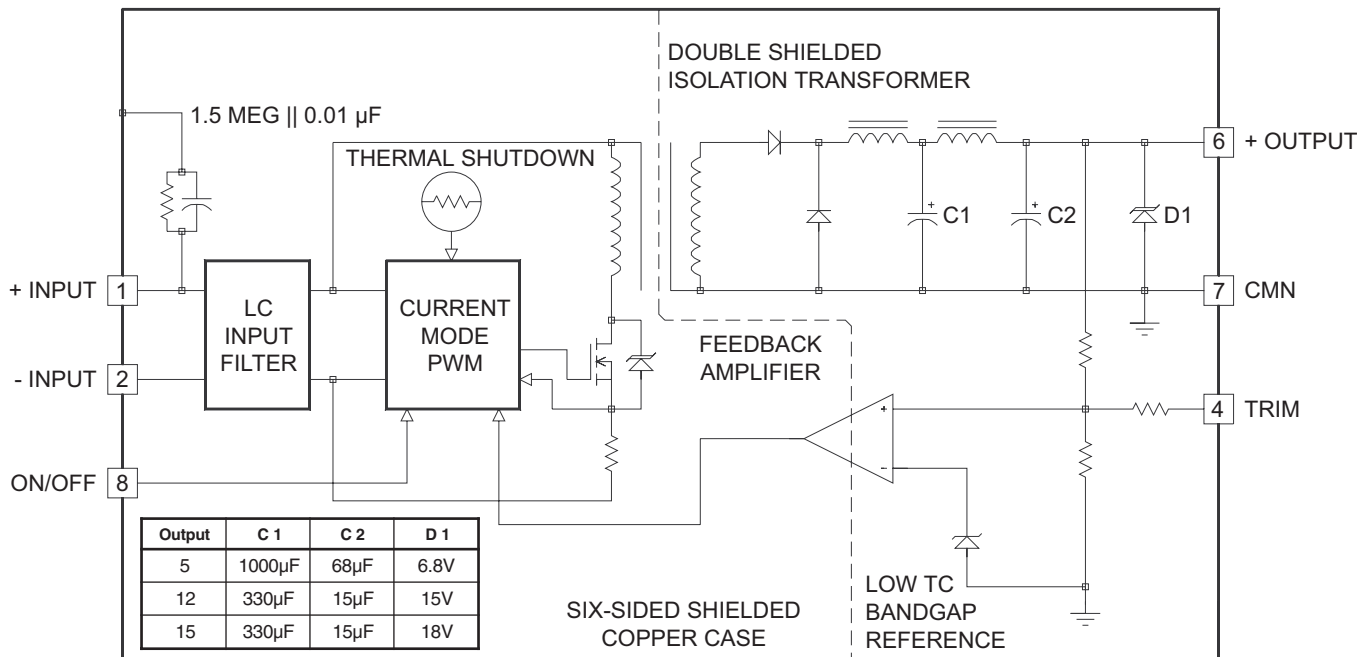

15 Watt XC Single Series DC/DC Converters

Input Parameters*								
Model		12S5.3000XC	12S12.1250XC	12S15.1000XC	48S5.3000XC	48S12.1250XC	48S15.1000XC	Units
Voltage Range	MIN	9.0			24.0			VDC
	MAX	27.0			72.0			
Reflected Ripple, 0-20MHz bw	TYP	100			50			mA P-P
	MAX	200			100			
Input Current Full Load No Load	TYP	1600	1540	1520	395	390	380	mA
	TYP	20	30	30	15	20	20	
Efficiency	TYP	789	81	82	79	80	82	%
Switching Frequency	TYP	70						kHz
Maximum Input Overvoltage, 100ms No Damage	MAX	32			85			VDC
Undervoltage Lockout		8.5			17			VDC
Turn-on Time, 1% Output Error	TYP	15						ms
Recommended Fuse		(2)						

Output Parameters*					
Model		12S5.3000XC 48S5.3000XC	12S12.1250XC 48S12.1250XC	12S15.1000XC 48S15.1000XC	Units
Output Voltage		5	12	15	VDC
Rated Current (3)	MIN	0	0	0	mA
	MAX	3000	1250	1000	
Voltage Range 100% Load	MIN	4.95	11.90	14.90	VDC
	TYP	5.00	12.00	15.00	
	MAX	5.05	12.10	15.10	
Load Regulation 0-100% Load	TYP	0.1			%
	MAX	0.5			
Line Regulation Vin = Min-Max VDC	TYP	0.05			%
	MAX	0.2			
Short Term Stability (4)	TYP	0.02			%
Long Term Stability	TYP	0.2			%/kHrs
Transient Response (5)	TYP	30	40	40	µs
Dynamic Response (6)	TYP	130	250	175	mV peak
Input Ripple Rejection (7)	TYP	60			dB
Noise, 0-20MHz bw	TYP	20			mV P-P
	MAX	50			
Temperature Coefficient	TYP	50			ppm/°C
	MAX	150			
Overvoltage Clamp (8)	TYP	6.8	15	18	VDC
Short Circuit Protection to Common for all Outputs		Continuous, 8 Hours Minimum Current Limnit and Thermal Overload			

NOTES

* All Parameters measured at Tc=25°C, nominal input voltage and full rated load unless otherwise noted. Refer to the CALEX Application Notes for the definition of terms, measurement circuits and other information.

- (2) Determine the correct fuse size by calculating the maximum DC current drain at low line input, maximum load then adding 20 to 25 percent. Slow blow type recommended.
- (3) No minimum load required.
- (4) Short term stability is specified after a 30 minute warm-up at full load, and with constant line, load and ambient conditions.
- (5) The transient response is specified as the time required to settle from 50 to 75% step load change (rise time of step = 2µSec.) to a 1% error band.
- (6) Dynamic response is the peak overshoot voltage during the transient response time defined in note 5 above.

- (7) The input ripple rejection is specified for DC to 120Hz ripple with a modulation amplitude of 1% Vin.
- (8) For module protection only, also see note 2.
- (9) The logic shutdown pin is Open Collector TTL, CMOS, and relay compatible. The input to this pin is referenced to input minus and is protected to +100VDC.
- (10) The functional temperature range is intended to give an additional data point for use in evaluating this power supply. At the low functional temperature the power supply will function with no side effects, however, sustained operation at the high functional temperature will reduce expected operational life. The data sheet specifications are not guaranteed over the functional temperature range.
- (11) The case thermal impedance is specified as the case temperature rise over ambient per package watt dissipated.
- (12) Water Washability - Calex DC/DC converters are designed to withstand most solder/wash processes. Careful attention should be used when assessing the applicability in your specific manufacturing process. Converters are not hermetically sealed.

15 Watt XC Single Series DC/DC Converters

General Specifications*			
All Models			Units
Logic Shutdown (9)			
ON Logic Level or Leave Pin open	MIN	5.5	VDC
OFF Logic Level	MAX	1.5	VDC
Input Resistance	TYP	10	kohms
Converter Idle Current, Shut Down Pin Low	TYP	3	mA
Isolation			
Isolation Voltage	MIN	500	VDC
Input-Output	MIN	250	VDC
Input-Case			
10µA Leakage			
Input to Output Capacitance	TYP	160	pF
Output Trim Function			
Input Resistance	TYP	15	kohms
Programming Range	MIN	±10	%
Environmental			
Case Operating Range	MIN	-25	°C
No Derating	MAX	80	°C
Case Functional Range (10)	MIN	-40	°C
	MAX	90	°C
Storage Range	MIN	-55	°C
	MAX	100	°C
Thermal Impedance (11)	TYP	4.4	°C/Watt
Thermal Shutdown Case Temperature	TYP	90	°C
General			
Unit Weight	TYP	7.0	oz
Mounting Kit		MS9	

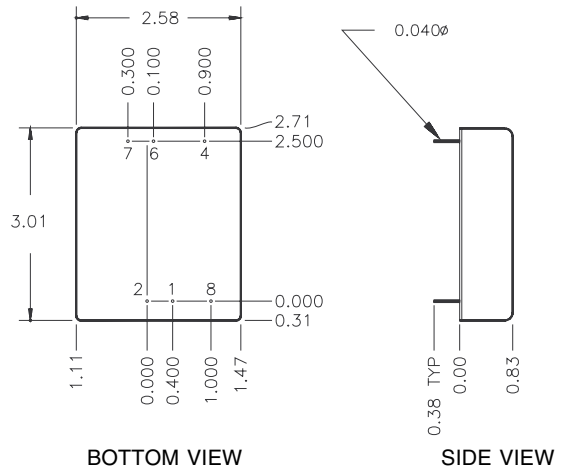

Mechanical tolerances unless otherwise noted:

X.XX dimensions: ±0.020 inches

X.XXX dimensions: ±0.005 inches

Seal around terminals is not hermetic. Do not immerse units in any liquid.

Pin	Function
1	+INPUT
2	-INPUT
4	OUTPUT TRIM
6	+OUTPUT
7	CMN
8	ON/OFF

Typical Performance (Tc=25°C, Vin=Nom VDC, Rated Load).

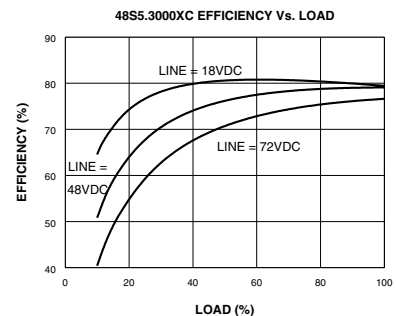
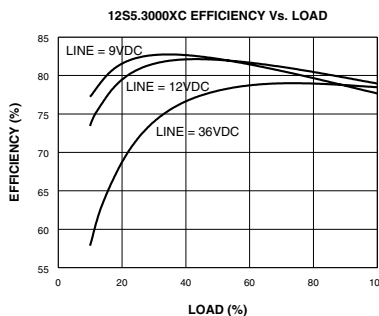
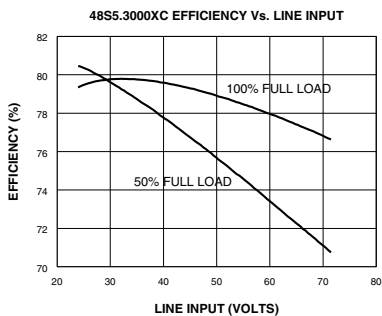
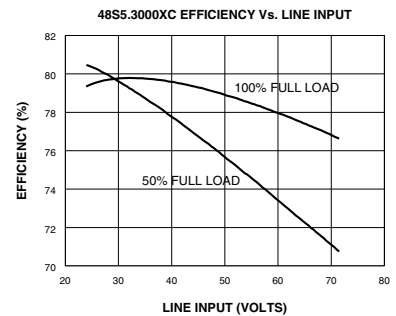
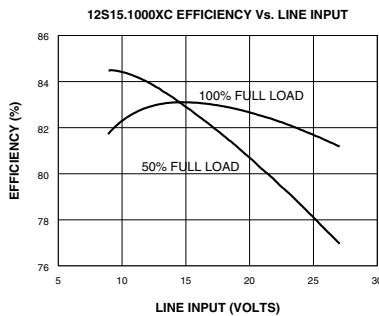
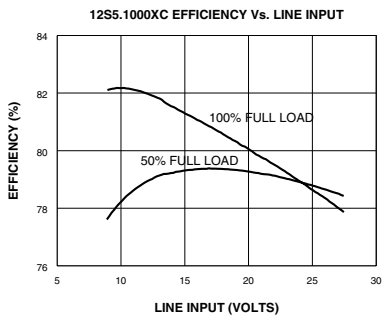

15 Watt XC Single Series DC/DC Converters

Typical Performance ($T_c=25^\circ\text{C}$, $V_{in}=\text{Nom VDC}$, Rated Load).

