

# 40 Watt XT Dual Series DC/DC Converters



## Features

- Fully Shielded/Filtered Design
- Lowest Noise Outputs, 70 mV P-P
- Very Low and Specified Reflected Ripple Current
- Very Low I/O Capacitance, 500 pF Typical
- Water Washable Shielded Copper Case
- 5 Year Warranty

## Description

These dual output converters are designed for ultra wide input range low noise telecommunications, industrial, and instrument applications. The very wide input range (4:1) is ideal for battery or unregulated input applications while the low noise complements even the most sensitive analog circuitry.

These converters are state of the art 220 kHz MOSFET based designs that provide outstanding regulation and conversion efficiencies of over 85%.

Remote ON/OFF and output voltage trim functions are also included.

As with all CALEX converters the 40 Watt XT Dual series is covered by our 5 Year Warranty.

Selection Chart					
Model	Input Range VDC		Output		
	Min	Max	VDC	mA	Power W
24D5.3000XT	9	36	±5	±3000	30
24D12.1500XT	9	36	±12	±1500	36
24D15.1200XT	9	36	±15	±1200	36
48D5.3500XT	20	72	±5	±3500	35
48D12.1700XT	20	72	±12	±1700	41
48D15.1300XT	20	72	±15	±1300	39

40 Watt XT Dual Series Block Diagram

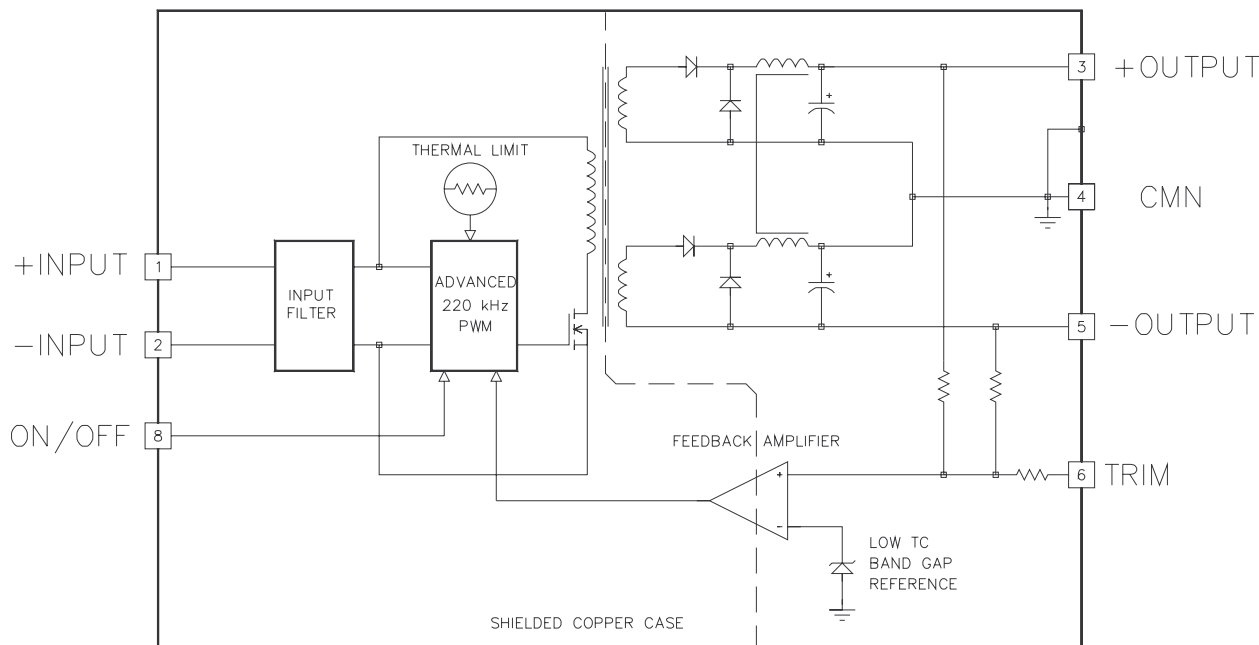

# 40 Watt XT Dual Series DC/DC Converters

Input Parameters*								
Model		24D5.3000XT	24D12.1500XT	24D15.1200XT	48D5.3500XT	48D12.1700XT	48D15.1300XT	Units
Voltage Range	MIN	9			20			VDC
	MAX	36			72			
Input Current	Full Load	1550	1820	1835	885	1010	960	mA
	No Load	15	20	20	15	15	15	
Efficiency	TYP	81	82	82	82	85	85	%
Reflected Ripple (1)	TYP	80	50	50	40	55	55	mA P-P mA RMS
	TYP	8.5	10	10	6.5	7.0	7.0	
Switching Frequency	TYP	220						kHz
Maximum Input Overvoltage, 100ms Maximum	MAX	45			80			VDC
Turn-on Time, 1% Output Error	TYP	40	30	30	40	30	30	ms
Recommended Fuse		(2)						AMPS

Output Parameters*								
Model		24D5.3000XT	24D12.1500XT	24D15.1200XT	48D5.3500XT	48D12.1700XT	48D15.1300XT	Units
Output Voltage		±5	±12	±15	±5	±12	±15	VDC
Output Voltage Accuracy	MIN	4.950	11.900	14.900	4.950	11.900	14.900	VDC
	TYP	5.000	12.000	15.000	5.000	12.000	15.000	
	MAX	5.050	12.100	15.100	5.050	12.100	15.100	
Rated Load Range (3)	MIN	0	0	0	0	0	0	mA
	MAX	±3000	±1500	±1200	±3500	±1700	±1300	
Load Regulation: 25% Max Load to Max Load (4)	TYP	0.4	0.1		0.4	0.1		%
	MAX	1.0	0.5		1.0	0.5		
Cross Regulation (5)	TYP	2.5	0.8		2.5	0.8		%
Line Regulation Vin = Min-Max VDC	TYP	0.1						%
	MAX	0.2						
Short Term Stability (6)	TYP	< 0.05						%/24Hrs
Long Term Stability	TYP	< 0.1						%/kHrs
Noise, Peak - Peak (1)	TYP	130	70	70	120	130	100	mV P-P
RMS Noise	TYP	40	15	30	35	35	30	mV RMS
Temperature Coefficient	TYP	50						ppm/°C
	MAX	250						
Short Circuit Protection		Output to Common and Thermal Protection (11)						

## NOTES

\* All parameters measured at Tc = 25°C, nominal input voltage and full rated load unless otherwise noted. Refer to the CALEX Application Notes for the definition of terms, measurement circuits and other information.

- (1) Noise is measured per CALEX application notes. Measurement bandwidth is 0-20 MHz. RMS noise is measured over a 0.01-1 MHz bandwidth. To simulate standard PCB decoupling practices, output noise is measured with a 10µf, tantalum and 0.01µF, ceramic capacitor located 1 inch away from the converter. Input ripple is measured into a 10µH source impedance.
- (2) See our application note for picking the correct fuse size.
- (3) The converter may be safely operated at any load from zero to the full rating. Dynamic response of the converter will degrade if the converter is operated with less than 25% output load.
- (4) Load regulation is defined for loading/unloading both outputs simultaneously. Load range is 25 to 100%.
- (5) Cross regulation is defined for loading/unloading one output while the other output is kept at full load. Load range is 25 to 100%.
- (6) Short term stability is specified after a 30 minute warmup at full load, constant line and recording the drift over a 24 hour period.
- (7) Case is tied to the CMN output pin.
- (8) The functional temperature range is intended to give an additional data point for use in evaluating this power supply. At the low functional temperature the power supply will function with no side effects, however sustained operation at the high functional temperature may reduce the expected operational life. The data sheet specifications are not guaranteed over the functional temperature range.
- (9) The case thermal impedance is specified as the case temperature rise over ambient per package watt dissipated.
- (10) Specifications subject to change without notice.
- (11) 12V and 15V output models are protected for overloads of greater than 2 ohms only.
- (12) Water Washability - Calex DC/DC converters are designed to withstand most solder/wash processes. Careful attention should be used when assessing the applicability in your specific manufacturing process. Converters are not hermetically sealed.

# 40 Watt XT Dual Series DC/DC Converters

General Specifications*				
All Models				Units
<b>ON/OFF Function</b>				
ON Logic Level or Leave Pin Open	MIN	4		VDC
OFF Logic Level or Tie Pin to -Input	MAX	1.0		VDC
Open Circuit Voltage	TYP	5		VDC
Input Resistance	TYP	6		kohms
Converter Idle Current ON/OFF Pin Low	TYP	7		mA
<b>Isolation (7)</b>				
Isolation Voltage				VDC
Input to Output, 24D	MIN	700		
Input to Output, 48D	MIN	1544		
10µA Leakage				
Input to Output Capacitance	TYP	500		pF
<b>Output Trim Function</b>				
Trim Range	MIN	±10		%
Input Resistance	MIN	10		kohms
<b>Environmental</b>				
Case Operating Range	MIN MAX	-40 85		°C
Case Functional Range (8)	MIN MAX	-55 90		°C
Storage Range	MIN MAX	-55 105		°C
Thermal Shutdown Case Temperature	TYP	100		°C
Thermal Impedance (9)	TYP	4.4		°C/Watt
Unit Weight	TYP	7		oz
<b>Mounting Options</b>				
Chassis Mounting Kit		MS9		
-I Suffix on Part Number		Inserts In Case		
-HS Suffix on Part Number		Heat Sink Option		

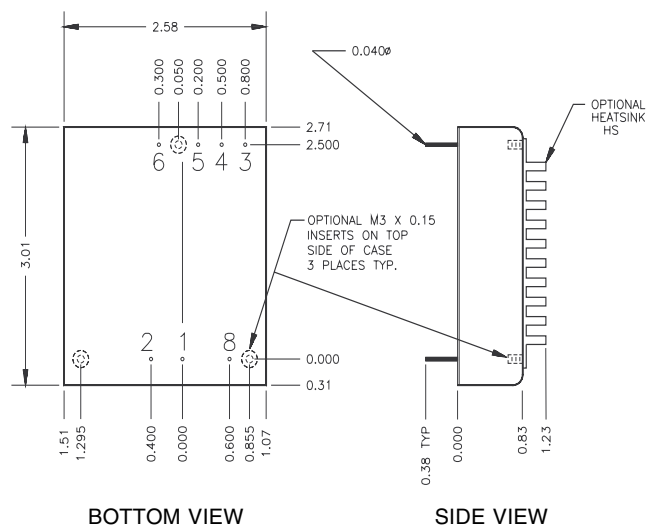

Mechanical tolerances unless otherwise noted:

X.XX dimensions: ±0.020 inches

X.XXX dimensions: ±0.005 inches

Pin	Function
1	+INPUT
2	-INPUT
3	+OUTPUT
4	CMN
5	-OUTPUT
6	TRIM
8	ON/OFF

## Applications Information

You truly get what you pay for in a CALEX converter, a complete system oriented and specified DC/DC converter - no surprises, no external noise filtering circuits needed, no heatsinking problems, just "plug and play".

The 40 Watt XT Dual series like all CALEX converters carries the full 5 year CALEX no hassle warranty. We can offer a five year warranty where others can't because with CALEX it's rarely needed.

Keep reading, you'll find out why.

## General Information

The XT Dual series is mindful of battery operation for industrial, medical control and remote data collection applications. The remote ON/OFF pin places the converter in a very low power mode that draws typically less than 10 mA from the input source.

Noise has also achieved new lows in this design, while the industry standard is to specify output noise as 1 to 5% peak to peak typical with no mention of measurement bandwidth. The XT converters are fully specified and tested to a wide bandwidth of 0-20 MHz.

Input filtering reduces reflected ripple noise and is similarly low and also fully specified for typical values (exact value depends on input voltage range). Typical RMS noise over a 10 kHz to 1 MHz bandwidth is specified for both the input and output.

Full overload protection is provided by independent pulse-by-pulse current limiting and an over-temperature shutdown circuit. These protection features assure you that our XT Dual will provide you with zero failure rate operation.

Five sided shielding is standard along with specified operation over the full industrial temperature range of -40 to +85°C case temperature.

# 40 Watt XT Dual Series DC/DC Converters

## Applying The Input

Figure 1 shows the recommended input connections for the XT Dual DC/DC converter. A fuse is recommended to protect the input circuit and should not be omitted. The fuse serves to prevent unlimited current from flowing in the case of a catastrophic system failure.

No external capacitance on the input is required for normal operation, in fact it can degrade the converters performance. Normal RF bypass capacitors in the 1000 pF to 0.01  $\mu$ F range may be used without harm.

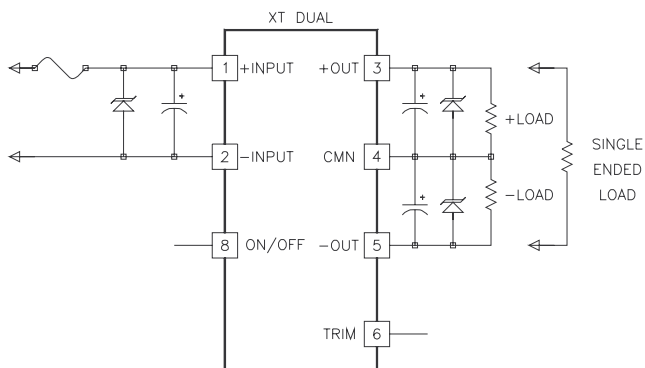
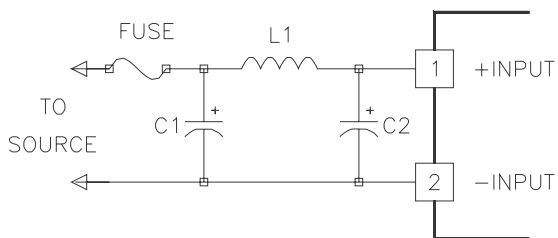

Figure 1.

Standard connections for the XT Dual. The ON/OFF and TRIM pins may be left floating if they are not used. The input protection fuse should not be omitted. If desired, external transient protection diodes can be used. See the text below for suggestions regarding input and output capacitance. The load may also be operated in "Single ended" mode as shown.

## Ultra Low Noise Input Circuit

The circuit shown in figure 2 can be used to reduce the input noise to below 20 mA p-p over a 20 MHz bandwidth. It is important to size inductor L1 appropriately for the maximum expected load current and input voltage. Capacitor C1 should be the moderate ESR type specified. The use of a very low ESR capacitor should be avoided as this will make a high-Q filter when we really want a low-Q, controlled cutoff filter.



- L1 = 50 $\mu$ H
- C1 = 10 $\mu$ F/100V, 0.25 - 1 OHM ESR
- C2 = 10 $\mu$ F/100V, 0.25 - 1 OHM ESR

Figure 2.

This circuit may be used to reduce the input reflected ripple to less than 20 mA p-p. Capacitor C1 should be the moderate ESR type shown to prevent input filter response peaking. Size the current carrying capability of L1 for the maximum expected load and minimum input operating voltage.

## Remote ON/OFF Pin Operation

The remote ON/OFF pin may be left floating if this function is not used. The equivalent input circuit for the ON/OFF pin is shown in figure 3. The best way to drive this pin is with an open collector/drain or relay contact. See our application note titled "Understanding the remote ON/OFF function" for more information about using the remote ON/OFF pin.

When the ON/OFF pin is pulled low with respect to the -Input, the converter is placed in a low power drain state. The ON/OFF pin turns the converter off while keeping the input bulk capacitor fully charged, this prevents the large inrush current spike that occurs when the +input pin is opened and closed.

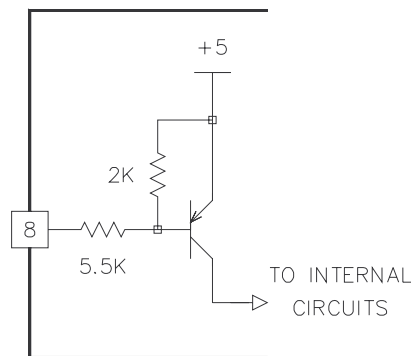

Figure 3.

The simplified schematic of the XT Dual series ON/OFF pin. The input impedance is approximately 6 k ohms. By leaving this pin floating the converter will be in the ON state. When the pin is pulled below 1.0 volts (with respect to the -Input pin) the converter is placed in the power down or OFF state. See our application note on the remote ON/OFF function for more information.

## Applying The Output

Figure 1 shows typical output connections for the XT Dual. In most applications no external output capacitance will be necessary. Only your normal 1 to 10  $\mu$ F and 0.001 to 0.1  $\mu$ F bypass capacitors sprinkled around your circuit as needed locally are required. Do not add extra output capacitance and cost to your circuit "Just Because".

If you feel you must add external output capacitance, do not use the lowest ESR, biggest value capacitor that you can find! This can only lead to reduced system performance or oscillation. See our application note "Understanding Output Impedance For Optimum Decoupling" for more information or use the ultra low noise output circuit below.

## Output Trimming

The trim pin may be used to adjust the outputs from the nominal factory setting. The trim may be used to adjust for system wiring voltage drops. Figure 4 shows the proper connections to use the trim pin. If output trimming is not desired the trim pin may be safely left floating.

Trimming the output up reduces the output current proportionally to keep the maximum power constant. Output current is not increased over the listed maximum when trimming the output voltage down.

# 40 Watt XT Dual Series DC/DC Converters

Down trim can actually reduce the minimum input voltage in some circuits. Full up trim may not be achievable at minimum input voltage and full rated load.

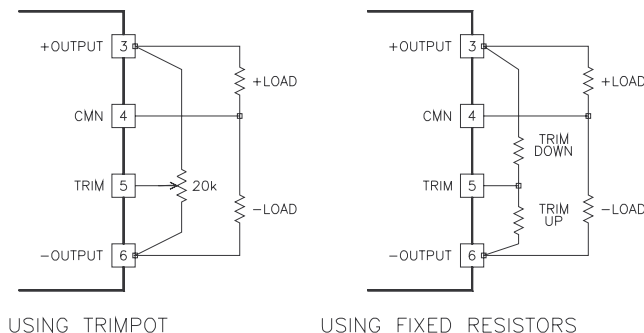

**FIGURE 4.**

The output can be trimmed by either a trimpot or fixed resistors. If fixed resistors are used their values may range from 0 to infinite ohms. The trimpot should be typically 20 k ohms.

## Non Standard Output Voltages

The XT Duals will typically trim much lower than the -10% specified. This allows the XT's to be trimmed lower than specified for RF or other special applications.

The 5 volt XT's can be typically trimmed over a range of 3.9 to 5.6 volts. The 12 volt XT's can be typically trimmed over a range of 6.4 to 13.3 volts. The 15 volt XT's can be typically trimmed over a range of 6.7 to 16.9 volts.

## Single Ended 10, 24 or 30 V Outputs

The dual outputs may also be used in a single ended mode as shown in figure 1 to get 10, 24 or 30 volts of output at the full rated power levels. To use the single ended mode just connect your load to the + and - Output pins and leave the CMN pin floating. Trimming of the outputs may also be done while using the single ended mode.

## Ultra Low Noise Output Circuit

The circuit shown in figure 5 can be used to reduce the output noise to below 20 mV p-p over a 20 MHz bandwidth. Size the inductors appropriately for the maximum expected load current.

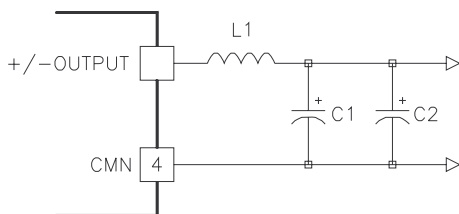

L1 = 20uH  
C1 = 1000uF/25V, ALUMINUM  
C2 = 47uF/25V, TANTALUM

**Figure 5.**

For very low noise applications this circuit will reduce the output noise to less than 20 mV p-p over a 0-20 MHz bandwidth. Be sure to size the inductor appropriately for the maximum expected load current.

## Operation With Very Light Loads

The dynamic response of the XT Dual will degrade when the unit is operated with less than about 25% of full rated power.

## Grounding

The input and output sections are fully floating from each other. They may be operated fully floating or with a common ground. If the input and output sections are connected either directly at the converter or at some remote location from the converter it is suggested that a 3.3 to 10  $\mu$ F, 0.5 to 5 Ohm ESR capacitor bypass be used directly at the converter output pins. This capacitor prevents any common mode switching currents from showing up at the converters output as normal mode output noise. See "Applying the Output" for more information.

Another "Trick" that can be used when operating with a common ground is to use a 10 to 100  $\mu$ H choke between the grounds. This gives you a solid low frequency ground connection, but looks like a high impedance to the switching current effects and prevents them from flowing in the connection. This will have the effect of preventing the common mode currents from showing up as normal mode components in your input or output circuits.

Be sure that the inductor has a self resonant frequency of greater than 200 kHz and that the Q of the inductor is quite low. If necessary to keep the inductor Q under control, parallel it with a 200 to 1 k ohm resistor.

## Case Grounding

The copper case serves not only as a heat sink but also as a EMI shield. The 0.25 inch thick case provides >30 dB of absorption loss to both electric and magnetic fields at 220 kHz, while at the same time providing 20 to 40 % better heat sinking over competitive thin steel, aluminum or plastic designs.

The case shield is tied to the output CMN pin. This connection is shown on the block diagram. The case is floating from the input sections. The input is coupled to the outputs only by the low 500 pF of isolation capacitance. This low I/O capacitance insures that any AC common mode noise on the inputs is not coupled to your output circuits.

Compare this isolation to the more usual 1000 - 2000 pF found on competitive designs and you will see that CALEX provides the very best DC and AC isolation available. After all, you are buying an isolated DC/DC to cut ground loops. Don't let the isolation capacitance add them back in.

## Temperature Derating

The XT Dual series can operate up to 85°C case temperature without derating. Case temperature may be roughly calculated from ambient by knowing that the XT Duals case temperature rise is approximately 4.4°C per package watt dissipated.

For example: If an XT converter is outputting 35 Watts, at what ambient could it expect to run with no moving air and no extra heatsinking?

# 40 Watt XT Dual Series DC/DC Converters

Efficiency is approximately 80%, this leads to an input power of 44 Watts. The case temperature rise would be 9 Watts x 4.4 = 40°C. This number is subtracted from the maximum case temperature of 85°C to get: 45°C.

This example calculation is for an XT Dual without any extra heat sinking or appreciable air flow. Both of these factors can greatly effect the maximum ambient temperature (see below). Exact efficiency depends on input line and load conditions, check the efficiency curves for exact information.

This is a rough approximation to the maximum ambient temperature. Because of the difficulty of defining ambient temperature and the possibility that the loads dissipation may actually increase the local ambient temperature significantly, these calculations should be verified by actual measurement before committing to a production design.

## Heat Sinking

The XT Dual can be ordered in a “-I” configuration which provides a case with 3 X M3 inserts located on the top surface of the case for attaching a heat sink or mounting the converter on it’s back using the inserts provided. The mounting surface should be flat to within ±0.01 inches to prevent warping the XT Dual’s case.

The CALEX HS heat sink was specially developed for this model and can reduce the case temperature rise to typically

below 3.3° C per watt with natural convection and less with moving air. It also increases the heat removing efficiency of any cooling air flow.

When the XT Dual is ordered with a HS option, CALEX will ship the converter and heatsink attached. One heat sink is needed for each converter ordered.

Customer installed heat sinks may also be used. It is recommended that either liquid heatsink compound or nothing be used on the heatsink interface. Stay away from the so called “Dry” pad heat sink materials, in our experience these materials are actually worse than no compound at all. Test them thoroughly before committing to production.

Additional heatsinking will lower internal temperatures and increase the expected operational life.

## Mounting Kit

The MS9 chassis mounting kit allows for direct wire connection to the XT Dual series pins. The mounting kit includes two barrier strips for wire attachment. The MS9 may be conveniently attached to a chassis by use of the 4 - 0.156 inch diameter mounting holes provided at each corner.

Although the MS9 comes with solderless sockets, for improved reliability in severe environmental or vibration environments it is recommended that the XT Dual be soldered to the mounting kit.

Typical Performance (Tc=25°C, Vin=Nom VDC, Rated Load).

