

# Model 433 Bridgesensor



## Features

- Complete Strain Gage Bridge Signal Conditioner
- Isolated 4-20 mA or 0-20 mA Output
- Output Capable of Driving 1000 ohm Loop
- Bridge Balance with 80% Tare Offset Capability
- High Gain Amplifier; Can Accept Full Scale Live Load Signals as Low as 5 mV and Provide 16 mA Output Span
- Excitation Supply Capable of Driving Four Load Cells
- AC Powered
- Rugged Epoxy Encapsulated Design

## Description

The Model 433 is a self contained, AC powered signal conditioner for bridge type instrumentation. It contains a precision instrumentation amplifier with isolated, filtered output and a highly regulated, low noise, adjustable output bridge excitation source. The unit is completely encapsulated for use in rugged environments.

## Applications

- Weighing with Load Cells
- Process Control Add-on Loops
- Can Be Used With All Types of Low Output Sensors

433 Block Diagram

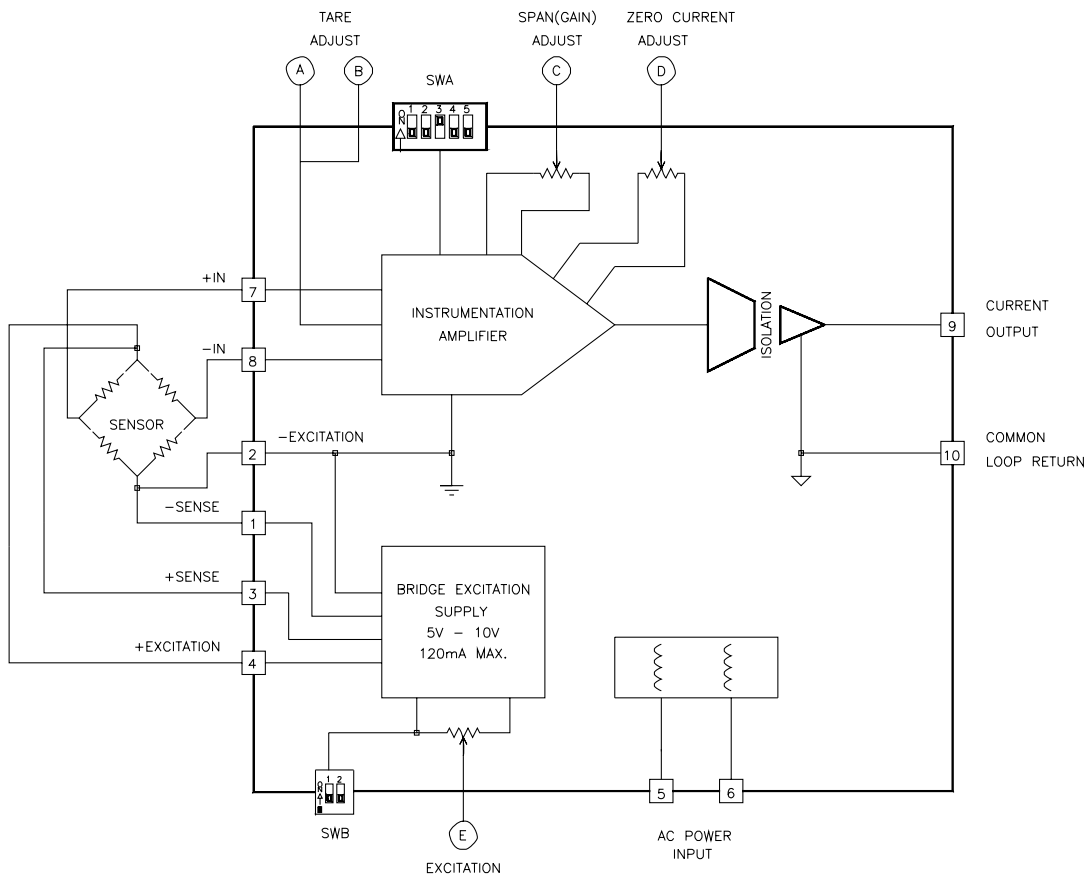

# Model 433 Bridgesensor

## Specifications

NOTE: Unless otherwise noted, specifications apply after one hour warm up at 25°C ambient. Temperature coefficients apply between 0°C and 55°C ambient.

<b>Isolation</b>	
Input to Output	700 VDC 60pF
<b>Amplifier</b>	
<b>Gain</b>	
Adjustment Range Input for 4 - 20 mA Output	5 mV to 50 mV
Linearity	±0.01% of Full Scale
Temperature Stability	50 PPM (0.005%/°C)
<b>Input Noise</b>	
.1 Hz to 10 Hz	2µV P-P
<b>Tare Adjustment Range</b>	
Bridge Offset	-3 mV to +25 mV (Equals 80% F.S. of 3 mV/V cell)
<b>Input Resistance</b>	
Differential and Common Mode	1000 megohm
<b>Common Mode Rejection, DC</b>	100 dB minimum
<b>Common Mode Input</b>	+ 5 Volts
<b>Output</b>	
<b>Zero Adjust</b>	0 or 4 mA
Temperature Coefficient	1µA/°C
<b>Current Output Span</b>	4 to 20 mA or 0 to 20 mA
Compliance Voltage	-1 to +20 Volts
Current	-1 mA to +20 mA
Loop Resistance	0 to 1000 ohms
Frequency Response, -3dB	10 Hertz, 2 Pole Roll Off
<b>Response Time</b>	
Rise Time 10% to 90%	35 ms
To 0.1% of Final Value	100 ms
<b>Bridge Supply</b>	
<b>Voltage Adjustment Range</b>	5 to 10 Volts
Temperature Coefficient	100 PPM Typical
Fixed	10.2V ±2.5%
Temperature Coefficient	60 PPM Typical
<b>Load Current</b>	0 to 120 mA
<b>Regulation - Load and Line</b>	0.02% maximum
<b>Output Noise</b>	
120 Hz Bandwidth	1 mV RMS, maximum
<b>Power Input</b>	115 VAC, ±10V 50/60 Hz @ 7 VA
Optional	220 or 230 VAC, ±10%
<b>Line Isolation</b>	
Capacitance	60 pF
Dielectric Withstand	1100 Volts RMS
<b>Environment</b>	
Ambient Operating	-25°C to +55°C
Storage	-25°C to +85°C
<b>Weight</b>	18 oz. (510 grams)
<b>Size</b>	3.75" L x 2.0" W x 2.87" H (9.53 cm x 5.1 cm x 7.62 cm)

## Getting Started with the Model 433

1. Excitation Supply. If remote sensing is not used, connect +Sense to +Excitation, terminal 3 to 4, and connect -Sense to -Excitation, terminal 1 to 2.
2. Apply power to the Model 433 and adjust the Excitation supply. Turn SWB-1 "ON" for a fixed 10 Volts. This will set the supply to 10.2±2.5% and provide the best temperature stability. For voltages between 5 and 10 Volts, place SWB-1 in the "OFF" position and set the Excitation Supply with potentiometer E. SWB-2 may be in either position.
3. Turn the power to the Model 433 off and connect the load cell to the Model 433 Excitation terminals and the Amplifier Inputs.
4. Turn on power to the 433.
5. Turn SWA-3 "ON". (To set output ZERO current with pot D.)
6. Select the expected full scale signal range according to the table with SWA-4 and SWA-5. If the output from the load cell is not known, set both SW-4 and SW-5 "ON" for the 40-50mV range.
7. Set SWA-2 "OFF" for 4mA or SWA-2 "ON" for 0mA output ZERO.
8. Adjust D potentiometer for desired ZERO current.
9. Turn SWA-3 "OFF". Expect output current to change.
10. Apply no load or dead weight to load cell.
11. Adjust TARE potentiometers A and B for the same ZERO current set in Step 8. SWA-1 "OFF" provides a bridge output balance of -3mV to +15mV, and "ON" between +15mV and +25mV.
12. Apply full scale load and adjust SPAN (GAIN) potentiometer C for the desired full scale output current. Set Range switches SWA-4 and SWA-5 as required.
13. Remove full scale load and check ZERO output current. Adjust FINE TARE potentiometer A if required.
14. Recheck full scale as in Step 12.
15. End.

**Note:** If the amplifier is used without using the 433 Excitation Supply, the external power supply low side must be connected to the -EXCITATION terminal 2 on the Model 433, or one of the inputs must be tied to terminal 2, -EXCITATION. This provides a DC return path for the finite amplifier input current.

## Amplifier

The amplifier is a true differential input, low drift Instrumentation Amplifier with less than 100pA input current. It has a common mode range of 5 Volts with respect to the - EXCITATION supply terminal and a minimum of 100dB rejection of the

# Model 433 Bridgesensor

common mode voltage. The input amplifier and excitation supply are DC isolated from the AC line and the current output. The isolated output current source has a compliance of 20 Volts to allow the Model 433 to operate with zero to 1000 Ohms of loop resistance.

## Tare Weight Compensation

The Model 433 has two different zero controls. One is called the OUTPUT zero and can be set to 0mA or 4mA with SWA-2. The other zero control is called TARE. SWA-1 allows the selection of one of two TARE ranges, -3mV to 15mV or +15mV to +25mV. Potentiometers are available for COARSE and FINE TARE adjustments.

## Connecting to a Sensor

Any amplifier has a finite input current which must have DC return path to the amplifier power supplies. This path is automatically provided when the Model 433 Bridge Excitation Supply is used to excite the sensor. If an external supply is used, one side of the external supply must be connected to the Model 433 common, Terminal 2. Be sure that the common mode voltage limits are observed. This would generally limit the external power supply to 10 Volts assuming that half the voltage would be common mode, as is the case when exciting a full bridge.

When the full scale output of a sensor is measured in millivolts, say 10 millivolts, care must be exercised in wiring systems. At 10 millivolts full scale, each microvolt ( $10^{-6}$  volts) contributes 0.01% of full scale output. Wire connections can generate microvolts of potential due to contact potentials. These will also be thermoelectric potentials and thus vary with temperature differences. All wires used in connecting up the Model 433 should be of the same material. If any intervening connections are made such as a terminal block, the terminal block connecting points should have good thermal contact so they will always be at the same temperature and thus cancel each other.

## Transducer Excitation

The bridge excitation supply voltage is set by SWB-1 and potentiometer E. Set SWB-1 ON for a fixed 10 Volts. This will provide the best temperature stability. The supply can be adjusted between 5 and 10 Volts by setting SWB-1 OFF and adjusting potentiometer E. The supply will deliver up to 120mA current at any voltage setting to power up to four 350 ohm sensors.

## SWB - Excitation Voltage

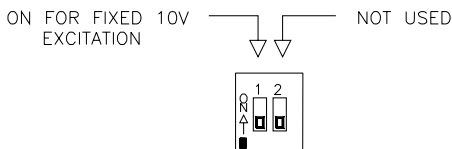

SWB-1	Excitation Voltage
ON	Fixed 10 Volts
OFF	Adjustable

## SWA - Control Switch

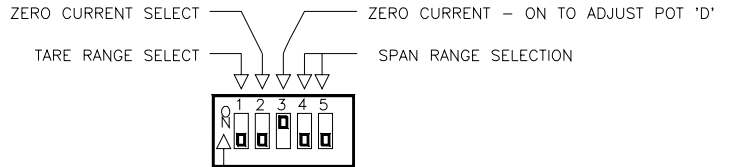

SWA-1	Tare Range
OFF	-3mV to +15 mV
ON	+15 mV to +25 mV

SWA-2	Zero Current
OFF	4 mA
ON	0 mA

SWA-4	SWA-5	Span Range
ON	ON	40 mV to 50 mV
OFF	ON	20 mV to 40 mV
ON	OFF	10 mV to 20 mV
OFF	OFF	5 mV to 10 mV

## Mechanical Specifications

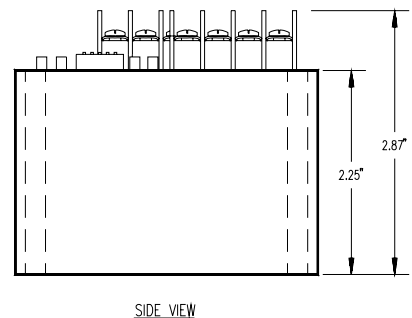
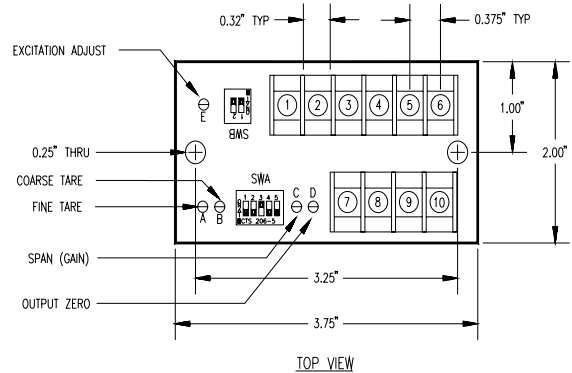

Terminal Strip Assignments			
Screw Terminal	Function	Screw Terminal	Function
1	-SENSE	6	AC
2	-EXCITATION	7	+SIGNAL
3	+SENSE	8	-SIGNAL
4	+EXCITATION	9	OUTPUT
5	AC	10	RETURN

# Model 433 Bridgesensor