

Model 436 Bridgesensor

Features

- Complete Strain Gage Bridge Signal Conditioner
- 4-20 mA or 12 ±8mA Output
- Contains Isolated DC/DC Converter
- Use with 0.5mV/V to 10mV/V Sensors
- Drives Four 350 ohm Bridges at 10 Volts
- Rugged Epoxy Encapsulated Design

Applications

- Weighing with Load Cells
- Process Control Add-on Loops
- Intrinsically Safe Applications
- Can Be Used With All Types of Low Output Sensors

Description

The Model 436 is a self contained, current output, DC powered signal conditioner for bridge type instrumentation. It contains a precision differential amplifier with filtered output and a highly regulated, low noise, adjustable output bridge excitation source. The Model 436 contains an isolated DC/DC converter which operates off 10 to 36 Volts DC. The unit is completely encapsulated for use in rugged environments.

436 Block Diagram

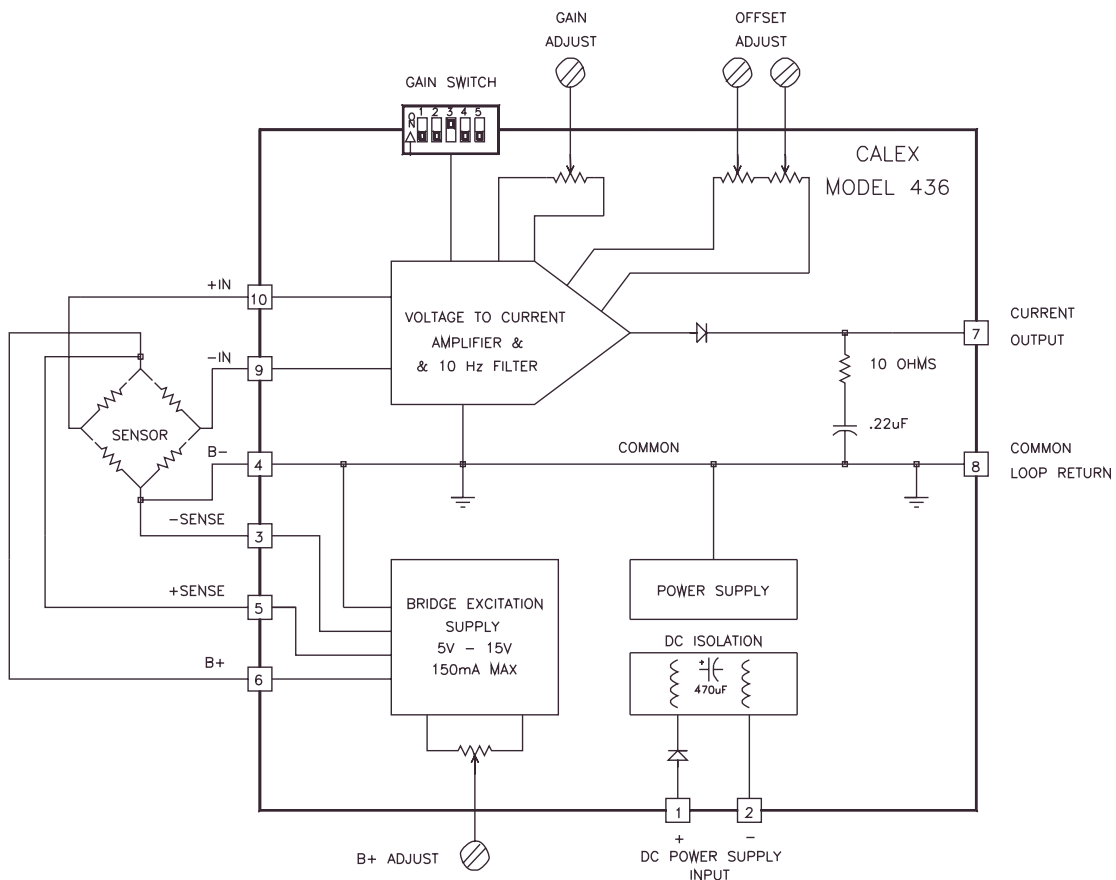

Model 436 Bridgesensor

Specifications

NOTE: Specifications apply 0°C to 55°C and 10 to 36 Volts DC input.

Output Current Span	4 to 20 mA; 12 ±8mA
Input for 16 mA Span	5 mV to 100 mV
Zero Adjust	±75% of span
Minimum Output	0 to 60 microamp
Temperature Coefficient	1 microamp/°C typical 4 microamp/°C maximum
Hysteresis	20 microamp maximum
Amplifier	
Cell Sensitivity (10 Volts Excitation)	0.5 mV/V to 10 mV/V
Linearity	0.005% typical
Temperature Stability	50 ppm/°C
Hysteresis	0.1% of span maximum
Input Bias Current	150 pA maximum
Input Noise: DC to 10 Hz	4 microvolts P-P maximum
Common Mode Input	0 to +7.5 Volts
Common Mode Rejection DC to 60 Hz	90 dB minimum
Output	
Current	0 to 20 mA
Loop Resistance	0 to 1000 ohm
Compliance	20 Volts maximum
Frequency Response	10 Hertz, 2 Pole Filter
Response Time to 0.1%	90 ms typical
Bridge Excitation Supply	
Adjustment Range	5 to 15 Volts
Load Current	150 mA maximum
Stability	100 ppm/°C maximum
Hysteresis	0.1%
Power Requirements	
Input power supply is DC isolated from the amplifier and is reverse polarity protected.	
Input Voltage	10 to 36 Volts DC
Input Current with 150mA B+ load with one 350 ohm Bridge	0.17A @ 36V to 0.7A @ 10V 0.1A @ 36V to 0.35A @ 10V
120 Hertz Ripple allowed on input supply	1 Volt P-P at 10 Volts input 2 Volts above 12 Volts input
Isolation	700 Volts DC & .0033 mF

Getting Started with the Model 436

This procedure is for large tare weights, i.e. greater than about 10% of the cell's full scale rating.

I. Hook Up Procedure

- A. Connect the + out of your load cell to the + INPUT, pin 10.
- B. Connect the - out of your load cell to the - INPUT, pin 9.

Note: If the ± SENSE are not used in your application, the connections in step C & D need to be followed. If the ± SENSE are going to be used, do not jumper them as described in steps C & D.

- C. Connect +Excitation, pin 6, to the + excitation of your load cell and jumper the + SENSE, pin 5, to +Excitation, pin 6.
- D. Connect -Excitation, pin 4, to the - excitation of your load cell and jumper the - SENSE, pin 3, to -Excitation, pin 4.
- E. Determine the voltage of the power supply to be used and adjust within the 10 to 36 volt range if necessary before connecting to the power pins, 1 and 2.
- F. Verify that the hook up procedure is complete.
- G. Turn on the power supply and check the bridge excitation supply.

II. Calibration Procedure

- A. Set the required load cell excitation voltage by using the B+ ADJUST.
- B. Set the GAIN SWITCH to the expected load cell output.
- C. Short the signal input pins 9 and 10 together with a clip lead. Adjust the COARSE and FINE OFFSET pots, C and B, 4 mA output current.
- D. Remove the short from step C.
- E. With no load on the cell, readjust the zero output.
- F. Apply the live load to the cell and adjust the GAIN, pot D, for the desired output current.
- G. Use the COARSE and FINE OFFSET pots to set the 4 mA output current.
- H. Repeat steps E. to G. until the desired settings are obtained.

Model 436 Bridgesensor

Amplifier

The built-in amplifier is a true differential input, low noise, low drift, instrumentation amplifier. It has a high common mode rejection ratio (CMRR) and is provided with an output offset that is potentiometer adjustable. The output offset pots adjust the output zero current up to 12 mA. The instrumentation amplifier has a gain DIP switch which changes the gain by factors of two and a gain potentiometer for fine adjustments.

The amplifier accepts input signals of 5 mV to 100 mV. The amplifier can withstand input voltages up to 15 Volts without damage. The output of the amplifier is filtered to be 3 dB down at 10 Hz using a double pole Butterworth filter to minimize the effects of high frequency electrical and physical noise on the system.

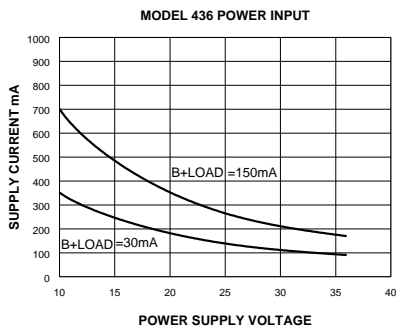

Bridge Excitation Supply

Transducer excitation is provided by an adjustable, well regulated, low noise power supply. The excitation voltage is adjustable by means of a molded-in potentiometer which allows the output voltage to be varied from 5 to 15 Volts. It is capable of supplying up to 150mA to drive up to five 350 ohm load cells at 10 Volts.

The B+ supply has remote sensing provisions for 6 wire configurations. The sense lines minimize variations in output voltage with changes in load current or lead resistance. It should be noted that if the sense feature is not being used, terminal 3 must be connected to terminal 4. Terminals 5 and 6 must be connected also. The supply output, B+, may be connected through a 300 ohm safety barrier and the sense lines will regulate the voltage across a 350 ohm bridge between 5 and 8 Volts.

The supply has short circuit protection to protect it against short term faults. The output recovers automatically from short circuit conditions once the short is removed.

Application

Figure A show a typical application using the remote sense lines and 4-20 mA output. When using shielded cable between the model 436 and the transducer, connect the shield to pin 4 only. Pin 4 is connected to Pin 8 inside the 436 module. Set the switch to the expected full scale output of the transducer as in figure B. With the 436 connected to a bridge, short the input, pins 9 and 10, and adjust the coarse and fine offset pots for 4.00 mA output. Then set the gain pot for full scale calibration. Recheck the zero current. If the zero current has changed, reset and set full scale.

The fault mode maximum output current will range from approximately 23 mA with 1000 ohms loop resistance to 55 mA into zero loop resistance.

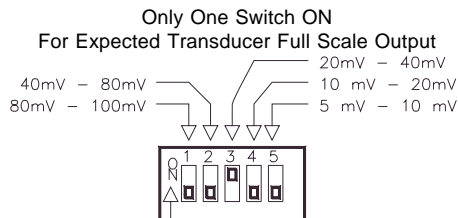

FIGURE B. Gain Range Switch

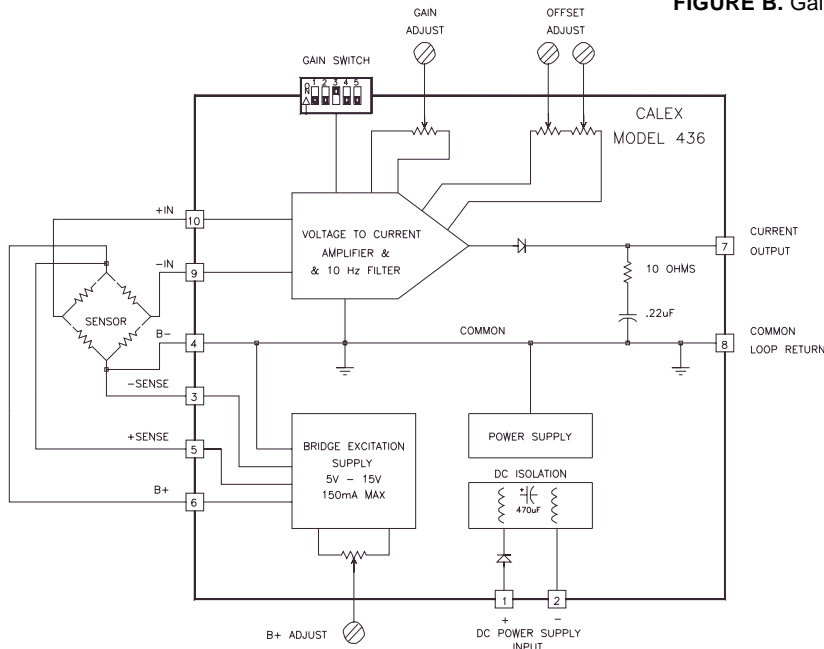

FIGURE A. Typical Application

Model 436 Bridgesensor

Mechanical Specifications

Specifically designed for rugged field use the Model 436 is completely encapsulated in epoxy using a vacuum potting system to insure a complete seal against corrosive environments. It is similarly protected against shock and vibration and will provide years of reliable accurate operation.

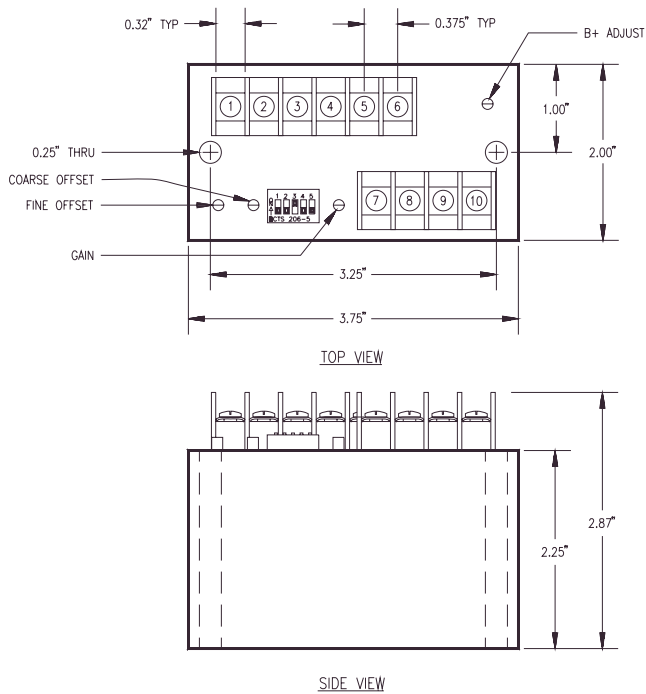

FIGURE C. Case Dimensions

Terminal Strip Assignments			
Screw Terminal	Function	Screw Terminal	Function
1	+DC POWER	6	B+
2	-DC POWER	7	CURRENT OUTPUT
3	-SENSE	8	AMPLIFIER CMN
4	B-	9	-INPUT
5	+SENSE	10	+INPUT