

5 Watt HW Single Series DC/DC Converters



Features

- Up to 5 Watts in 1.25" x 0.80" x 0.40" case
- Efficiencies to 84%
- Isolation Voltage up to 1544 VDC
- Water Washable Case Design
- Overcurrent Protection for Long, Reliable Operation
- Fully Self Contained,
No External Parts Required for Operation
- RoHS Compliant

Model	Input Range VDC		Output VDC	Output mA
	Min	Max		
12S1R5.1200HW	9	18	1.5	1200
12S1R8.1200HW	9	18	1.8	1200
12S2R5.1200HW	9	18	2.5	1200
12S3R3.1200HW	9	18	3.3	1200
12S5.1000HW	9	18	5	1000
12S12.425HW	9	18	12	425
12S15.350HW	9	18	15	350
24S1R5.1200HW	18	36	1.5	1200
24S1R8.1200HW	18	36	1.8	1200
24S2R5.1200HW	18	36	2.5	1200
24S3R3.1200HW	18	36	3.3	1200
24S5.1000HW	18	36	5	1000
24S12.425HW	18	36	12	425
24S15.350HW	18	36	15	350
48S1R5.1200HW	36	72	1.5	1200
48S1R8.1200HW	36	72	1.8	1200
48S2R5.1200HW	36	72	2.5	1200
48S3R3.1200HW	36	72	3.3	1200
48S5.1000HW	36	72	5	1000
48S12.425HW	36	72	12	425
48S15.350HW	36	72	15	350

Description

These 5 Watt DC/DC Converters were designed for fast integration with your systems power needs. With no external components or filtering necessary for all but the most critical applications, these converters can provide power instantly. This saves you costly engineering time required to design your system around the power converter.

5 Watt Single HW Series Block Diagram

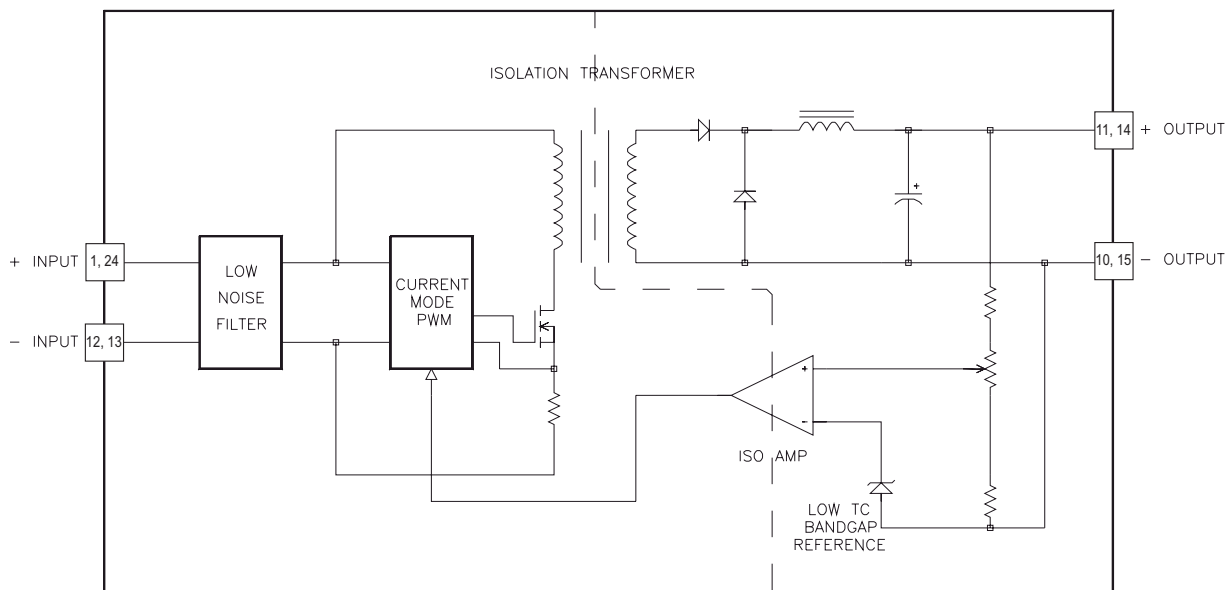

5 Watt HW Single Series DC/DC Converters

Input Parameters									
Model		12S1R5.1200HW	12S1R8.1200HW	12S2R5.1200HW	12S3R3.1200HW	12S5.1000HW	12S12.425HW	12S15.350HW	Units
Voltage Range (1)	MIN	9							VDC
	MAX	18							
Reflected Ripple	TYP	150							mA P-P
Input Current Full Load No Load	TYP	230	260	340	410	500	520	530	mA
	TYP	12	12	12	12	12	12	12	
Efficiency	TYP	65	69	73	81	83	82	83	%
Switching Frequency	TYP	400							kHz
Maximum Input Overvoltage, 100ms Maximum	MAX	24							VDC
Turn-on Time, 1% Output Error	TYP	45							ms
Recommended Fuse		(3)							AMPS

Input Parameters									
Model		24S1R5.1200HW	24S1R8.1200HW	24S2R5.1200HW	24S3R3.1200HW	24S5.1000HW	24S12.425HW	24S15.350HW	Units
Voltage Range (1)	MIN	18							VDC
	MAX	36							
Reflected Ripple	TYP	100							mA P-P
Input Current Full Load No Load	TYP	115	130	170	205	250	250	260	mA
	TYP	12	12	12	12	12	12	12	
Efficiency	TYP	65	69	73	81	83	84	84	%
Switching Frequency	TYP	400							kHz
Maximum Input Overvoltage, 100ms Maximum	MAX	45							VDC
Turn-on Time, 1% Output Error	TYP	45							ms
Recommended Fuse		(3)							AMPS

Input Parameters									
Model		48S1R5.1200HW	48S1R8.1200HW	48S2R5.1200HW	48S3R3.1200HW	48S5.1000HW	48S12.425HW	48S15.350HW	Units
Voltage Range (1)	MIN	36							VDC
	MAX	72							
Reflected Ripple	TYP	75							mA P-P
Input Current Full Load No Load	TYP	57	65	85	102	125	125	130	mA
	TYP	12	12	12	12	12	12	12	
Efficiency	TYP	65	69	73	81	83	84	84	%
Switching Frequency	TYP	400							kHz
Maximum Input Overvoltage, 100ms Maximum	MAX	85							VDC
Turn-on Time, 1% Output Error	TYP	45							ms
Recommended Fuse		(3)							AMPS

5 Watt HW Single Series DC/DC Converters

Output Parameters									
Model		12S1R5.1200HW	12S1R8.1200HW	12S2R5.1200HW	12S3R3.1200HW	12S5.1000HW	12S12.425HW	12S15.350HW	Units
Output Voltage	MIN	1.47	1.77	2.45	3.24	4.9	11.7	14.6	VDC
	TYP	1.50	1.80	2.50	3.33	5.0	12.0	15.0	
	MAX	1.53	1.84	2.55	3.42	5.1	12.3	15.4	
Rated Load Range	MIN	120	120	120	0	0	0	0	mA
	MAX	1200	1200	1200	1200	1000	425	350	
Load Regulation 25% Max Load - Max Load	TYP	1.2	1.0	0.5	0.5	0.2	0.2	0.2	%
	MAX	2.5	2.0	1.0	1.0	0.4	0.4	0.4	
Line Regulation Vin=Min-Max VDC	TYP	1.0	1.0	0.5	0.2	0.1	0.1	0.1	%
	MAX	2.0	2.0	1.0	0.4	0.2	0.2	0.2	
Transient Response (4)	TYP	250				300	500		µs
Dynamic Response (4)	TYP	75	100	100	150	250	350	500	mV peak
Noise, 0-20MHz bw Fundamental (2)	TYP	70	70	70	70	70	125	125	mV P-P
	TYP	45	45	45	45	45	70	70	
Temperature Coefficient (5)	TYP	200							ppm/°C
Short Circuit Protection to Common	Continuous, Current Limit								

Output Parameters									
Model		24S1R5.1200HW	24S1R8.1200HW	24S2R5.1200HW	24S3R3.1200HW	24S5.1000HW	24S12.425HW	24S15.350HW	Units
Output Voltage	MIN	1.47	1.77	2.45	3.24	4.9	11.7	14.6	VDC
	TYP	1.50	1.80	2.50	3.33	5.0	12.0	15.0	
	MAX	1.53	1.84	2.55	3.42	5.1	12.3	15.4	
Rated Load Range	MIN	120	120	120	0	0	0	0	mA
	MAX	1200	1200	1200	1200	1000	425	350	
Load Regulation 25% Max Load - Max Load	TYP	1.2	1.0	0.5	0.5	0.2	0.2	0.2	%
	MAX	2.5	2.0	1.0	1.0	0.4	0.4	0.4	
Line Regulation Vin=Min-Max VDC	TYP	1.0	1.0	0.5	0.2	0.1	0.1	0.1	%
	MAX	2.0	2.0	1.0	0.4	0.2	0.2	0.2	
Transient Response (4)	TYP	250				300	500		µs
Dynamic Response (4)	TYP	75	100	100	150	250	350	500	mV peak
Noise, 0-20MHz bw Fundamental (2)	TYP	70	70	70	70	70	125	125	mV P-P
	TYP	45	45	45	45	45	70	70	
Temperature Coefficient (5)	TYP	200							ppm/°C
Short Circuit Protection to Common	Continuous, Current Limit								

Output Parameters									
Model		48S1R5.1200HW	48S1R8.1200HW	48S2R5.1200HW	48S3R3.1200HW	48S5.1000HW	48S12.425HW	48S15.350HW	Units
Output Voltage	MIN	1.47	1.77	2.45	3.24	4.9	11.7	14.6	VDC
	TYP	1.50	1.80	2.50	3.33	5.0	12.0	15.0	
	MAX	1.53	1.84	2.55	3.42	5.1	12.3	15.4	
Rated Load Range	MIN	120	120	120	0	0	0	0	mA
	MAX	1200	1200	1200	1200	1000	425	350	
Load Regulation 25% Max Load - Max Load	TYP	1.2	1.0	0.5	0.5	0.2	0.2	0.2	%
	MAX	2.5	2.0	1.0	1.0	0.4	0.4	0.4	
Line Regulation Vin=Min-Max VDC	TYP	1.0	1.0	0.5	0.2	0.1	0.1	0.1	%
	MAX	2.0	2.0	1.0	0.4	0.2	0.2	0.2	
Transient Response (4)	TYP	250				300	500		µs
Dynamic Response (4)	TYP	75	100	100	150	250	350	500	mV peak
Noise, 0-20MHz bw Fundamental (2)	TYP	70	70	70	70	70	125	125	mV P-P
	TYP	45	45	45	45	45	70	70	
Temperature Coefficient (5)	TYP	200							ppm/°C
Short Circuit Protection to Common	Continuous, Current Limit								

5 Watt HW Single Series DC/DC Converters

General Specifications			
All Models			Units
Isolation			
Isolation Voltage			
Input to Output 12S, 24S	MIN	700	VDC
Input to Output 48S 10µA Leakage	MIN	1544	
Input to Output Capacitance	TYP	1500	pF
Environmental			
Case Operating Range	MIN	-40	°C
No Derating	MAX	90	
Case Functional Range (9)	MIN	-40	°C
	MAX	100	
Storage Range	MIN	-55	°C
	MAX	105	
Thermal Impedance (8)	TYP	30	°C/Watt
General			
Unit Weight	TYP	0.44	oz
Agency Approvals	UL 1950, CuL, EN60950 (TUV) pending		
MTBF	> 1 M Hours		

NOTES:

- All parameters measured at T_c=25°C, nominal input voltage and full rated load unless otherwise noted. Refer to the CALEX Application Notes for the definition of terms.
- Output Noise is measured with a 1µF tantalum capacitor and a 0.01µF ceramic capacitor across the output. The fundamental component of noise is at the switching frequency and also is commonly referred to as ripple.
- External fusing should be used for system protection due to a catastrophic failure. See CALEX Application Note 9 in the Calex DC/DC Catalog to determine correct fuse.
- Load Transient Overshoot is the output voltage peak amplitude referenced to the final value due to a step load change of 50-75% occurring only on the measured output. "Load Transient Overshoot" and "Dynamic Response" are the same specification. Load Transient Recovery Time is the time for the output to return to within specified voltage error band centered about the final value. "Load Transient Recovery Time" and "Transient Response" are the same specification.
- Temperature coefficient is defined for case temperatures. Output voltage deviation is calculated as the maximum resulting from either 1) 25°C case to maximum operating case temperature, or 2) 25°C case to minimum operating case temperature.
- Below the minimum rated load, the output may exhibit noise performance degradation. Operation with less than minimum rated load will not damage the unit, and the DC regulation is not significantly affected.
- The case thermal impedance is specified and the case temperature rise over ambient per package watt dissipated.
- Case functional temperature range is intended to give an additional data point for use in evaluating this power supply. At the low functional temperature the power supply will function with no side effects, however, sustained operation at the high functional temperature will reduce expected operational life. The data sheet specifications are not guaranteed over the functional temperature range.
- Specifications subject to change without notice.
- Water Washability - Calex DC/DC converters are designed to withstand most solder/wash processes. Careful attention should be used when assessing the applicability in your specific manufacturing process. Converters are not hermetically sealed.

(11) RoHS Compliant

RoHS Compliance means conformity to EU Directive 2002/95/EC of 27 January 2003, on the restriction of the use of certain hazardous substances in electrical and electronic equipment, lead, cadmium, mercury, hexavalent chromium, polybrominated biphenyls, and polybrominated diphenyl ethers are not present in quantities exceeding the following maximum concentrations in any homogeneous material, except for applicable exemptions. 0.1% (by weight of homogeneous material) lead, mercury, hexavalent chromium, polybrominated biphenyls, polybrominated diphenyl ethers, or 0.01% (by weight of homogeneous material) cadmium. The RoHS marking is as follows:



Mechanical Outline and Connector Pin Assignments

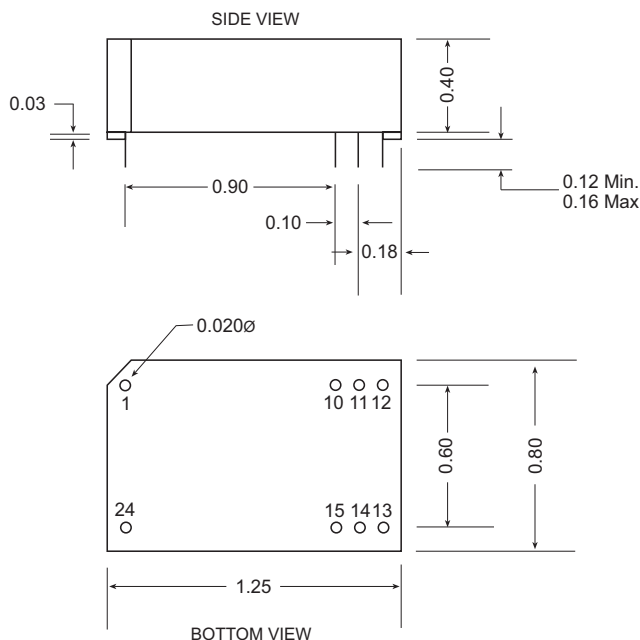

Mechanical tolerances unless otherwise noted:

X.XX dimensions: ±0.020 inches

X.XXX dimensions: ±0.010 inches

Pin location shown is for the mating PCB

Pin	Function
1	+INPUT
10	-OUTPUT
11	+OUTPUT
12	-INPUT
13	-INPUT
14	+OUTPUT
15	-OUTPUT
24	+INPUT