

75 WATT HE TRIPLE SERIES DC/DC CONVERTERS



Features

- Small size 2.4" x 2.28" x 0.53" half-brick package
 - Excellent Thermal Performance with metal baseplate
 - High Efficiency
 - Volt-seconds clamp and fast over voltage clamp
 - Pulse-by-pulse current limiting, short circuit frequency foldback
 - Over-temperature protection
 - Auto-softstart
 - Low Noise
 - Constant frequency for normal operation
 - 2:1 Input Voltage Range
 - Positive logic primary remote ON/OFF
 - Negative logic primary shutdown as an option
 - Very low temperature coefficient
 - Water Washable
 - Trimmable output voltage
 - Low Cost
 - 5 Year Warranty
 - Available in both RoHS and Non-RoHS construction.
- See ordering info below model selection chart.

Description

The Standard Triple HE DC/DC converter provides three regulated low voltage DC outputs at high efficiency and low cost. The unit has feedback from the +5 Vdc output. The auxiliary outputs are cross regulated to the main feedback loop (reference the block diagram). The Standard Triple HE meets rigorous requirements in an industry standard case size and is well suited for most telecommunication applications.

The Standard Triple HE includes primary remote on/off control plus threaded-through holes to allow easy mounting or the addition of a heat sink for high temperature use.

Selection Chart					
Model	Input Range VDC		lin ADC	Vout VDC	Iout ADC
	Min	Max	TYP		
24T5.12HE	18	36	3.63	5, ±12	15, ±2.0
24T5.15HE	18	36	3.60	5, ±15	15, ±2.0
48T5.12HE	36	75	1.80	5, ±12	15, ±2.0
48T5.15HE	36	75	1.79	5, ±15	15, ±2.0
48T5.17HE	36	75	1.78	5, ±17	15, ±2.0

The output currents are the maximum ratings of each of the outputs. It is up to the user to ensure that the total power output is below 75 Watts.

Default ON/OFF logic is positive.

Add -N to the model number to order negative ON/OFF logic.

To order RoHS, add (RoHS) to part number.

75 Watt HE Triple Series Block Diagram

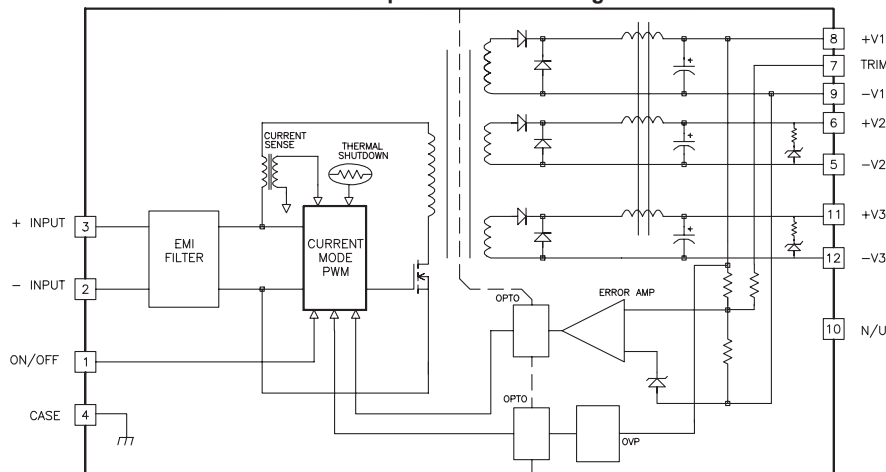

75 WATT HE TRIPLE SERIES DC/DC CONVERTERS



Unless otherwise stated, these specifications apply for baseplate temperature TB=23±2°C, nominal input voltage, and rated typ load. (1)

Input Parameters				
Model		24T5.12HE	24T5.15HE	Units
Voltage Range	MIN	18		V
	TYP	24		
	MAX	36		
Input Overvoltage (100 ms)	MAX	50		V
Input Ripple Rejection (120Hz)	TYP	50		dB
Undervoltage Lockout		Yes		
Input Reverse Voltage Protection		Yes		
Input Current	No Load	15		mA
	Typ Load	3.67		
Inrush Current	MAX	0.5		A ² s
Reflected Ripple, 12µH Source Impedance (3)	TYP	20		mA P-P
Efficiency	TYP	85	85	%
Switching Frequency	TYP	325		kHz
Recommended Fuse		(2)		A

Input Parameters					
Model		48T5.12HE	48T5.15HE	48T5.17HE	Units
Voltage Range	MIN	36			V
	TYP	48			
	MAX	75			
Input Overvoltage (100 mSec)	MAX	85			V
Input Ripple Rejection (120Hz)	TYP	50			dB
Undervoltage Lockout		Yes			
Input Reverse Voltage Protection		Yes			
Input Current	No Load	12			mA
	Typ Load	1.8			
Inrush Current	MAX	0.5			A ² s
Reflected Ripple, 12µH Source Impedance (3)	TYP	20			mA P-P
Efficiency	TYP		88	89	%
Switching Frequency	TYP	325			kHz
Recommended Fuse		(2)			A

Notes:

- (1) Refer to the CALEX Application Notes for the definition of terms, measurement circuits, and other information.
- (2) These units are not fused and need to be fused by the user. Refer to the CALEX Application Notes for information of fusing. For inrush current, refer to the specifications above.
- (3) 33µF capacitor connected between the two "Input" pins. Then insert current sensor in series with 12µH inductor between 33µF and the source. The reflected ripple current is measured over a 5 Hz to 20 MHz bandwidth. Noise should be minimized in the measurement.
- (4) Noise is measured per the CALEX Application Notes. Output noise is measured with a 10µH tantalum capacitor in parallel with a 0.1 µF ceramic capacitor connected across the output to CMN. Measurement bandwidth is 0-20MHz.
- (5) Optimum performance is obtained when this power supply is operated within the minimum to maximum load specifications. No damage to module will occur, when the output is operated at less than minimum load, but the output voltage may contain a low frequency component that may exceed output noise specifications. Total output power must not exceed 75W.
- (6) Load Transient Recovery Time is defined as the time for the output to settle from a 50% to 75% or 25% step load change to a 1% error band (rise time of step = 2µs).
- (7) Load Transient Overshoot is defined as the peak overshoot during a transient as defined in the Note 6 above.
- (8) Load regulation is defined as the output voltage change when simultaneously changing all outputs from typ. to min load and noting the change. The voltage is measured at the output pin.
- (9) Cross regulation is defined as the change in one output (set at 70% of maximum load) when only one of the other outputs is changed for 70% of maximum to 20% of maximum load.
- (10) Most switches would be suitable for the logic ON/OFF control. In case there is a problem you can make the following estimations and then leave some margin.
When open collector is used for logic high, "Open Circuit Voltage at ON/OFF Pin", "Output Resistance" and "External Leakage Current Allowed for Logic High" are used to estimate the high impedance requirement of open collector.
When switch is used for logic low, "Open Circuit Voltage at ON/OFF Pin", "Output Resistance" and "LOW Logic Level" are used to estimate the low impedance requirement of the switch.

Continued on page 4.



75 WATT HE TRIPLE SERIES DC/DC CONVERTERS



Unless otherwise stated, these specifications apply for baseplate temperature TB=23±2°C, nominal input voltage, and rated typ load. (1)

Output Parameters (VO1)				
Model		24T5.12HE 24T5.15HE	48T5.12HE 48T5.15HE 48T5.17HE	Units
Output Voltage		5		V
Output Voltage Setpoint Accuracy @ Typ Load	MAX	±1		%
Turn On Overshoot Min-Max Load	TYP	0		%
Temperature Coefficient	TYP	0.003		%/ ^o C
	MAX	0.01		
Noise and Ripple RMS (4)	TYP	100		mV P-P mV RMS
	TYP	50		
Load Current (5) (12)	MIN	1.5		A
	TYP	10		
	MAX	15		
Load Transient Overshoot (7)	TYP	4		%
Load Transient Recovery Time (6)	TYP	200		µs
Load Regulation (5) Min-Typ Load	TYP	1		%
	MAX	1.2		
Line Regulation Vin = Min-Max	TYP	0.01		%
	MAX	0.1		
Overvoltage Protection (OVP) Threshold OVP Type - Non-latching Open Loop Overvoltage Clamp	TYP	130		%
Output Current Limit Vout = 90% of Vout-nom	TYP	120		%
Output Short Circuit Current Vout = 0.25V	MAX	175		%

Output Parameters (VO2, VO3)							
Model		24T5.12HE	48T5.12HE	24T5.15HE	48T5.15HE	48T5.17HE	Units
Output Voltage		±12		±15		±17	V
Output Voltage Setpoint Accuracy @ Typ Load	MAX	±5.5					%
Turn On Overshoot Min-Max Load	TYP	0					%
Temperature Coefficient	TYP	0.02					%/ ^o C
	MAX	0.05					
Noise and Ripple RMS (4)	TYP	150	150	200	200	200	mV P-P mV RMS
	TYP	100	100	150	150	150	
Load Current (5) (12)	MIN	0.2		0.2		0.2	A
	TYP	1.041		0.833		0.735	
	MAX	2.0		2.0		2.0	
Load Transient Overshoot (7)	TYP	4					%
Load Regulation (5) Min-Typ Load	TYP	3.5					%
	MAX	5					
Line Regulation Vin = Min-Max	TYP	0.5					%
	MAX	1					
Cross Regulation (9)	TYP	4					%
Absolute Regulation	TYP	8					%
Output Voltage Protection Open Loop Overvoltage Clamp		Yes (Volt-Seconds Clamp)					%



75 WATT HE TRIPLE SERIES DC/DC CONVERTERS



General Specifications			
All Models			Units
Primary Remote ON/OFF Function			
HIGH Logic Level for ON	MIN	3.0	VDC
External Leakage Current Allowed for Logic High (14)	MAX	10	µA
Input Diode Protection Voltage	MAX	50	VDC
LOW Logic Level or Tie ON/OFF Pin to -INPUT	MAX	1.0	VDC
Sinking Current for Primary Logic Level	MAX	500	µA
Open Circuit Voltage at ON/OFF Pin (10)	TYP	2.3	VDC
Positive Logic	TYP	1.5	VDC
Negative Logic			
Output Resistance (10)	TYP	3	kΩ
Idle Current (Module is OFF)	TYP	2	mADC
Turn-on Time to 1% error	TYP	20	ms
Remote ON/OFF Logic (13)	HIGH - Module ON LOW - Module OFF		
Output Voltage Trim			
Trim Range	MIN MAX	±10	% of Vout
Input Resistance	TYP	10	kΩ
Open Circuit Voltage	TYP	2.5	V
Trim Limit			
Maximum Output Voltage	MAX	110	% of Vout
Isolation			
Input to Output Isolation 10µA Leakage Vnom = 24V Vnom = 48V	MIN MIN	700 1544	VDC VDC
Input to Output Resistance	MIN	10	MΩ
Input to Output Capacitance	TYP	1800	pF
Environmental			
Calculated MTBF, Bellcore Method 1, Case 1	>1,000,000		h
Baseplate Operating Temperature Range	MIN MAX	-40 100	°C
Storage Temperature	MIN MAX	-40 120	°C
Thermal Impedance (11)	TYP	7	°C/W
Thermal Shutdown Baseplate Temperature (Auto Restart)	TYP	110	°C
General			
Unit Weight	TYP	4.6/114	oz/g
Case Dimension	2.4" x 2.28" x 0.53"		
Torque on Mounting Inserts	MAX	12 in. oz.	
Agency Approvals	Designed to Meet UL60950		
Chassis Mounting Kit	MS25		

- (11) Thermal impedance is tested with the converter mounted vertically and facing another printed circuit board 1/2 inch away. If converter is mounted horizontally with no obstruction, thermal impedance is approximately 7°C/W.
- (12) Minimum load is defined as 10% of maximum load. Calex Mfg. Co. Inc. does not guarantee performance for loads less than the minimum. Loads less than the minimum shall not damage the unit.
- (13) The unit can be configured with negative logic for Remote ON/OFF.
- (14) When an external On/Off switch is used, such as open collector switch, logic high requires the switch to be high-impedance. Switch leakage currents greater than 10µA may be sufficient to trigger the ON/OFF to the logic-low state.
- (15) When using the trim function, the user should remember that all three voltages will go up or down at the same time.
- (16) Water Washability - Calex DC/DC converters are designed to withstand most solder/wash processes. Careful attention should be used when assessing the applicability in your specific manufacturing process. Converters are not hermetically sealed.
- (17) Torque fasteners into threaded mounting inserts at 12 in. oz. or less. Greater torque may result in damage to unit and void the warranty.
- (18) RoHS Compliance:
See Calex Website www.calex.com/RoHS.html for the complete RoHS Compliance statement.
The RoHS marking is as follows. 

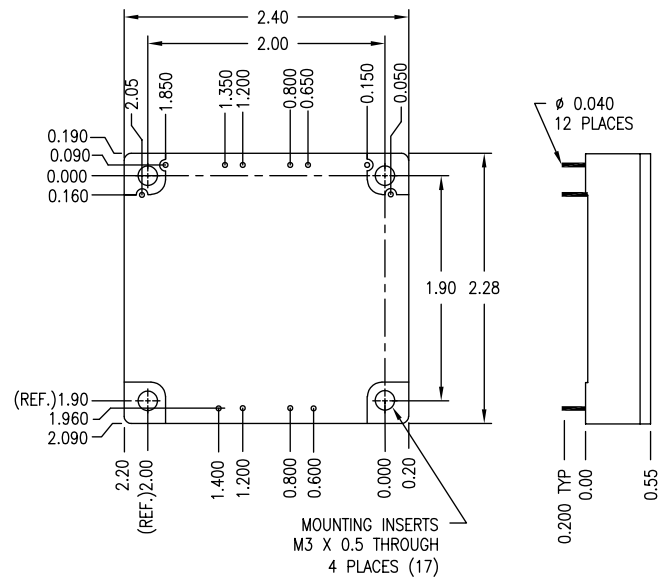

TOLERANCE: ALL DIMENSIONS ARE TYPICAL IN INCHES UNLESS OTHERWISE NOTED:	
X.XX	±0.020
X.XXX	±0.005

Pin	Function	Pin	Function
1	Primary ON/OFF	7	TRIM
2	-V IN	8	+ V1
3	+ VIN	9	- V1
4	CASE	10	N/U
5	- V2	11	+ V3
6	+ V2	12	- V3

