

Power Accessories - Heatsinks

HS26

- Designed for Quarter-Brick Modules
- Aluminum Material, Black Anodized
- Available either Longitudinal or Transverse
- RoHS Compliant

Longitudinal

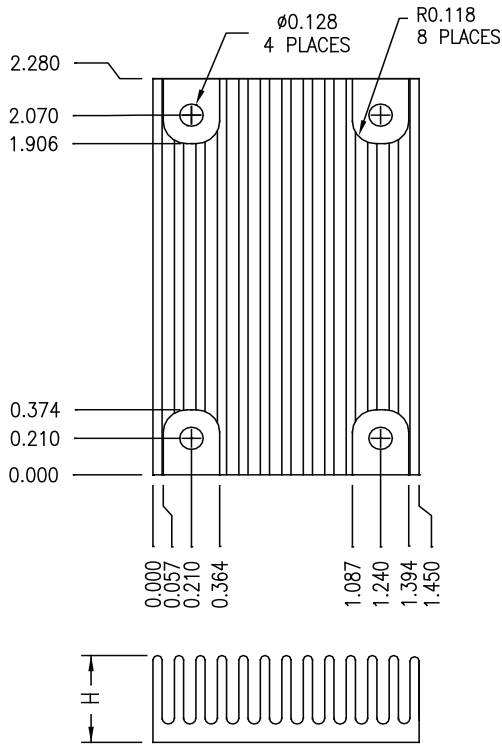

Part Number	Height	Number of Fins	Thermal Resistance @ 20 Watt Dissipated
HS26-5-L	0.5"	13	6.7°C / Watt
HS26-1-L	1.0"	10	3.3°C / Watt

Transverse

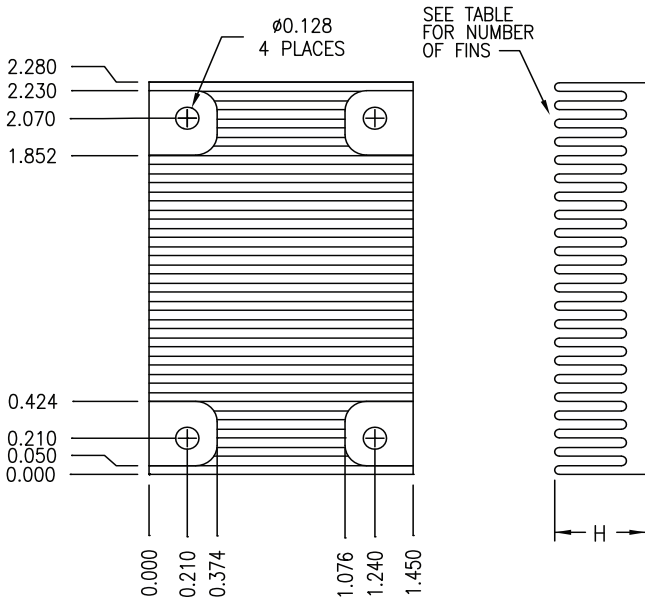

Part Number	Height	Number of Fins	Thermal Resistance @ 20 Watt Dissipated
HS26-5-T	0.5"	22	7.6°C / Watt
HS26-1-T	1.0"	16	3.8°C / Watt

Power Accessories - Heatsinks

HS35

- Excellent Thermal Properties
- Cast Aluminum, Alloy 383
- Finish: Black Anodized
- Low Cost
- Designed for standard Half Brick case size
- RoHS Compliant

Part Number	Height	Thermal Resistance @ 20 Watt Dissipated
HS-35	0.7"	1.54°C / Watt

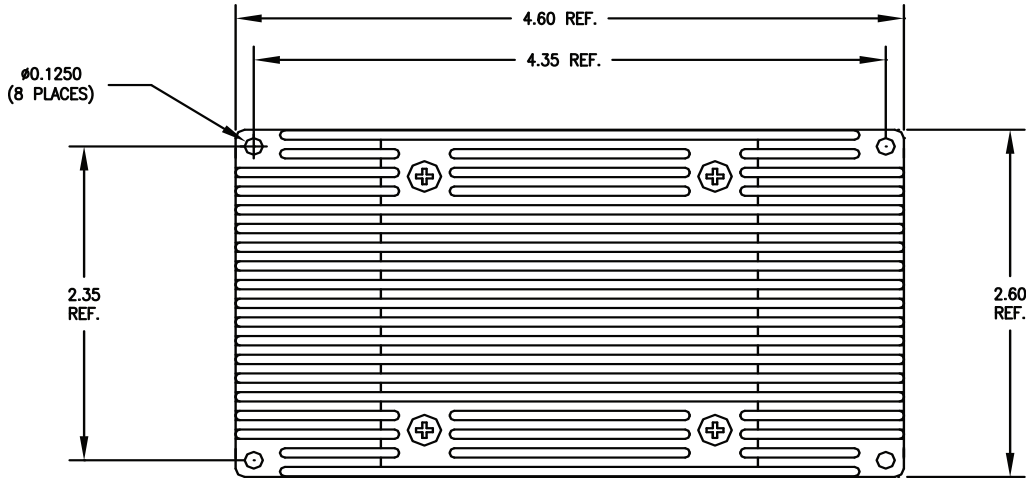

TOP VIEW

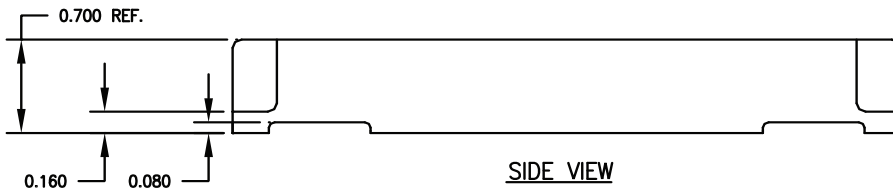

SIDE VIEW

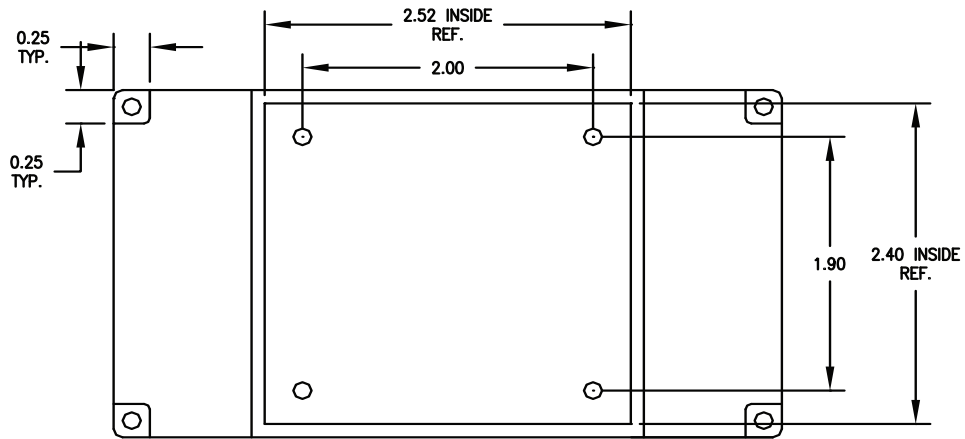

BOTTOM VIEW (OPEN END)

Power Accessories - Heatsinks

HS36

- Designed for Half Brick Modules
- Aluminum Material, Black Anodized
- RoHS Compliant

Part Number	Height	Number of Fins	Thermal Resistance @ 20 Watt Dissipated
HS36-5-L/T	0.45"	15	5.7°C / Watt
HS36-9-L/T	0.9"	12	3.2°C / Watt

Drawing referenced below is a representative of actual heatsink.

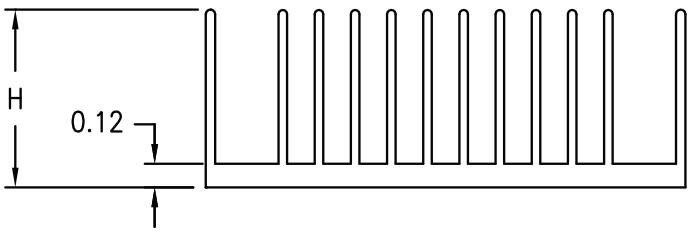
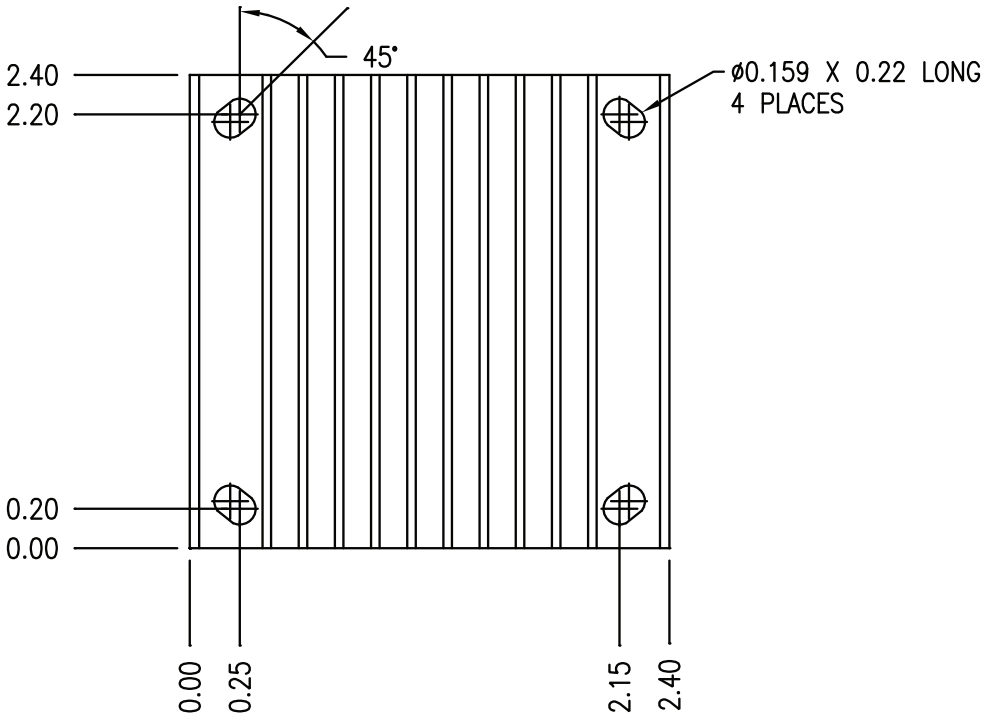

Power Accessories - Heatsinks

HS46

- Designed for Full-Brick Modules
- Aluminum Material, Black Anodized
- Available either Longitudinal or Transverse
- RoHS Compliant

Longitudinal

Part Number	Height	Number of Fins	Thermal Resistance @ 20 Watt Dissipated
HS46-5-L	0.5"	8	4.1°C / Watt
HS46-9-L	0.9"	8	2.4°C / Watt

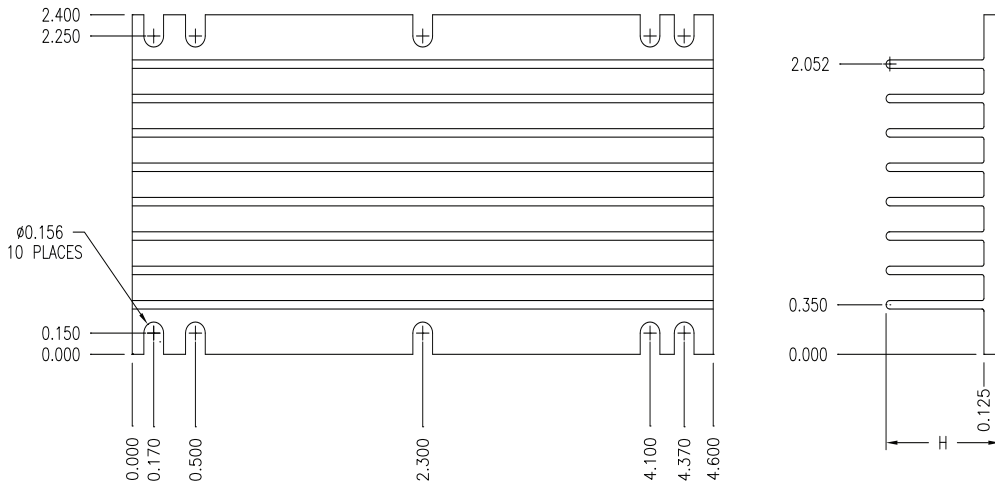

Transverse

Part Number	Height	Number of Fins	Thermal Resistance @ 20 Watt Dissipated
HS46-5-T	0.5"	16	4.2°C / Watt
HS46-9-T	0.9"	16	2.5°C / Watt

