

20 Watt HP Triple Series DC/DC Converters

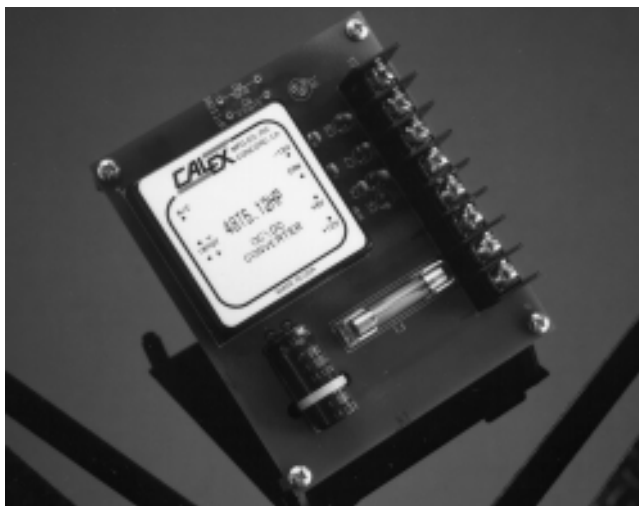

Features

- High Power Density with Efficiencies to 86%
- Lowest Noise Outputs, 50 mV P-P
- Very Low and Specified Reflected Ripple Current
- Very Low 400 pF I/O Capacitance
- Water Washable Shielded Copper Case

Description

The HP series is a high performance 20 watt triple output DC/DC converter designed for battery and telecom systems. The wide 2:1 input voltage ranges cover nearly any input voltage from 9 to 72 VDC.

The most popular +5 and ± 12 or ± 15 output voltages are provided in 6 models for your convenience. Other voltages may be factory ordered, contact CALEX applications engineering at 1-800-542-3355 for more information.

Available options include a fully filtered input version for use where the supply must operate in a low reflected noise environment. A thermal overload protection option makes the supply nearly bullet proof to any fault condition, including loss or blockage of your systems cooling!

Full application information is provided to make integrating this supply in your system a snap.

Selection Chart				
Model	Input Range VDC		Outputs VDC	Outputs mA MAX
	Min	Max		
12T5.12HP	9	18	5, ± 12	2500, ± 310
12T5.15HP	9	18	5, ± 15	2500, ± 250
24T5.12HP	18	36	5, ± 12	2500, ± 310
24T5.15HP	18	36	5, ± 15	2500, ± 250
*48T5.12HP	36	72	5, ± 12	2500, ± 310
*48T5.15HP	36	72	5, ± 15	2500, ± 250

*Agency Approvals: CSA/UL 60950

20 Watt HP Triple Series Block Diagram

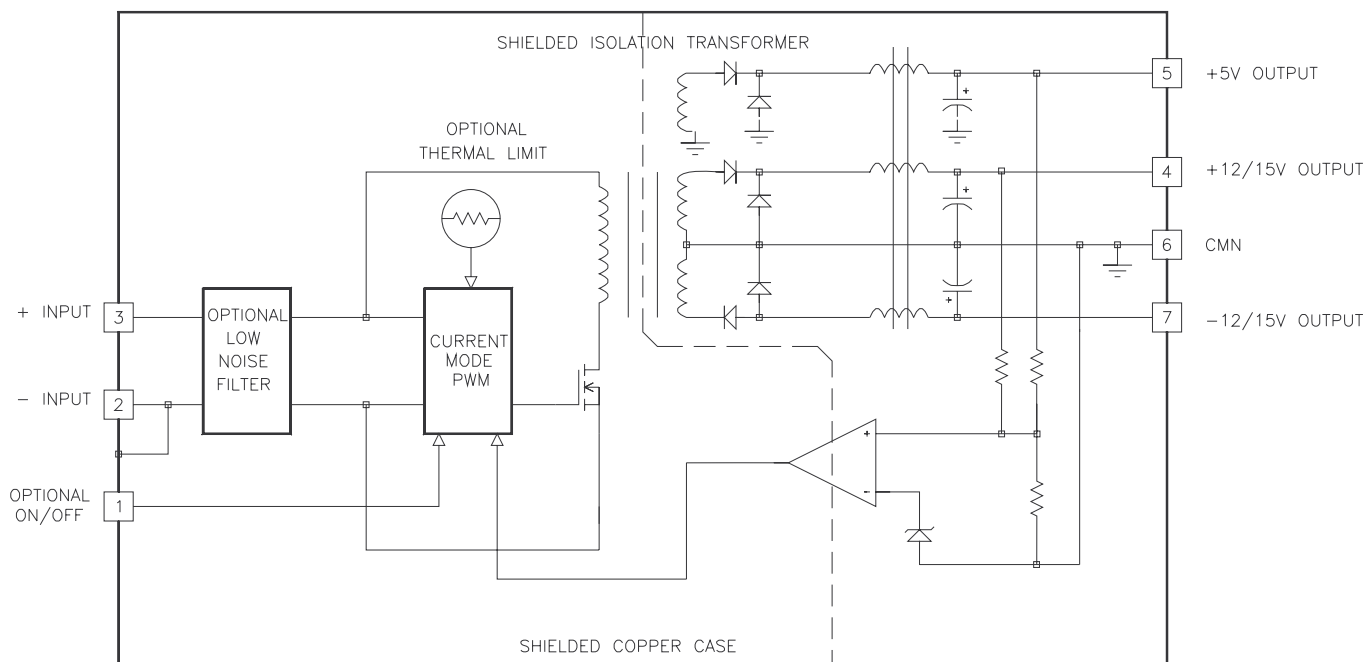

20 Watt HP Triple Series DC/DC Converters

Input Parameters*								
Model		12T5.12HP	12T5.15HP	24T5.12HP	24T5.15HP	48T5.12HP	48T5.15HP	Units
Voltage Range (1)	MIN	9.0		18.0		36.0		VDC
	MAX	18.0		36.0		72.0		
Reflected Ripple (2)	TYP	15		10		6		mA RMS
Input Current Full Load	TYP	2160		995		510		mA
	No Load	TYP	16	10		8		
Efficiency, Full Load	TYP	77		84		82		%
Switching Frequency	TYP	220						kHz
Maximum Input Overvoltage, 100ms No Damage	MAX	23		45		85		VDC
Turn-on Time	TYP	10						mSec

Output Parameters*							
Model		12T5.12HP 24T5.12HP 48T5.12HP	12T5.15HP 24T5.15HP 48T5.15HP	12T5.12HP 24T5.12HP 48T5.12HP	12T5.15HP 24T5.15HP 48T5.15HP	Units	
Output Voltage		+5		±12		±15	VDC
Rated Load (3)	MIN	600		75		60	mA
	MAX	2500		310		250	
Voltage Range 100% Load	MIN	4.925		11.700		14.700	VDC
	TYP	5.000		12.000		15.000	
	MAX	5.075		12.300		15.300	
Output Balance (Plus to Minus Output, Full Load)	TYP	N/A		< 50		< 50	mV
Load Regulation Min-Max Load (4)	TYP	< 0.5		< 1.0		< 1.0	%
	MAX	2.0		2.0		2.0	
Cross Regulation (5)	TYP	1.0		5.0		5.0	%
Line Regulation Vin = Min-Max VDC	TYP	0.1		0.4		0.4	%
	MAX	1.0		1.5		1.5	
Short Term Stability (6)	TYP	< 0.1		< 0.02		< 0.02	%
Transient Response (7)	TYP	2		0.5		0.5	mSec
Dynamic Response (8)	TYP	200		130		140	mV peak
Noise, 0-20MHz bw (2)	TYP	50		40		40	mV P-P
Temperature Coefficient	TYP	50		50		50	ppm/°C
	MAX	150		200		200	
Short Circuit Protection to CMN for all Outputs		Standard model - short term current limit, -FT option - Long term thermal protection					

NOTES

* All parameters measured at TC = 25°C, nominal input voltage and full rated load unless otherwise noted. Refer to the CALEX Application Notes for the definition of terms, measurement circuits and other information.

- (1) See the power derating curve for information on the 12T models available output power.
- (2) Noise is measured per CALEX application notes. Measurement bandwidth is 0 - 20 MHz. RMS noise is measured over a 0.01-1 MHz bandwidth. To simulate standard PCB decoupling practices, output noise is measured with a 1µF, tantalum and 0.01µF, ceramic capacitor located 1 inch away from the converter. Input ripple is measured into a 10µH source impedance. Input Reflected Ripple is for -FT option. For input ripple without the -FT option see the applications section.
- (3) Optimum performance is obtained when this power supply is operated within the minimum to maximum load specifications.
- (4) Output regulation is specified by simultaneously changing all outputs from minimum to maximum load and noting the change in each output.
- (5) Cross regulation is defined as the change in one output when only one of the other outputs is changed from maximum to minimum load.
- (6) Short term stability is specified after a 30 minute warm up at full load, constant line, load and ambient conditions.
- (7) Transient response is defined as the time for the output to settle from a 50 to 75% step load change to a 1% error band (rise time of step = 2µs).
- (8) Dynamic response is defined as the peak overshoot during a transient as defined in note 7 above.
- (9) The functional temperature range is intended to give an additional data point for use in evaluating this power supply. At the low functional temperature the power supply will function with no side effects. Sustained operation at the high functional temperature will reduce the expected operational life. The data sheet specifications are not guaranteed over the functional temperature range.
- (10) The case thermal impedance is specified as the case temperature rise over ambient per package watt dissipated.
- (11) Specifications subject to change without notice.
- (12) Water Washability - Calex DC/DC converters are designed to withstand most solder/wash processes. Careful attention should be used when assessing the applicability in your specific manufacturing process. Converters are not hermetically sealed.

20 Watt HP Triple Series DC/DC Converters

General Specifications*				
All Models				Units
Isolation				
Isolation Voltage				
Input to Output	12T, 24T	MIN	700	VDC
Input to Output	48T	MIN	1544	
10µA Leakage				
Input to Output Capacitance		TYP	400	pF
ON/OFF Function				
ON Logic Level or Leave Pin Open		MIN	> 1.6	VDC
OFF Logic Level or Tie Pin to -Input		MAX	< 0.7	VDC
Open Circuit Voltage		TYP	2.5	VDC
Input Resistance		TYP	20	kohms
Converter Idle Current ON/OFF Pin Low				
12T Models		TYP	13	mA
24T and 48T Models		TYP	14	mA
Environmental				
Case Operating Range No Derating		MIN	-40	°C
		MAX	90	
Case Functional Range (9)		MIN	-55	°C
		MAX	100	
Storage Range		MIN	-55	°C
		MAX	105	
Thermal Shutdown Case Temperature -FT option		TYP	105	°C
Thermal Impedance (10)		TYP	9.5	°C/Watt
General				
Unit Weight			< 3	oz
Chassis Mounting Kit			MS8	
Options				
- FT Suffix on Part Number			Filtered Input	
			Thermal Overload, ON/OFF Control	
Agency Approvals			CSA/UL 60950	

Applications Information

You truly get what you pay for in a CALEX converter, a complete system oriented and specified DC/DC converter - no surprises, just "plug and play".

Keep reading, you'll find out why.

General Information

The HP Triple series is mindful of battery operation for industrial, medical control and remote data collection applications. The optional remote ON/OFF pin (-FT option) places the converter in a very low power mode that draws typically less than 3 mA from the input source.

Noise has also achieved new lows in this design, while the industry standard is to specify output noise as 1 to 5% peak to peak typical with no mention of measurement bandwidth.

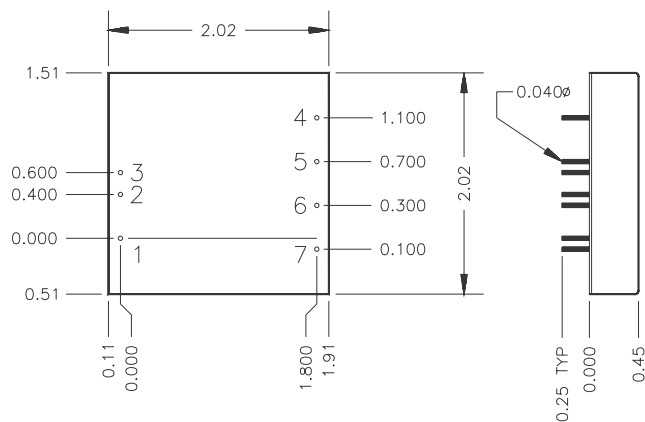

BOTTOM VIEW

SIDE VIEW

Mechanical tolerances unless otherwise noted:

X.XX dimensions: ±0.020 inches

X.XXX dimensions: ±0.005 inches

Pin	Function
1	OPTIONAL ON/OFF
2	-INPUT
3	+INPUT
4	+12/15V OUTPUT
5	+5V OUTPUT
6	CMN
7	-12/15V OUTPUT

The HP converters achieve 50 mV peak to peak typical and are fully specified and tested to a wide bandwidth of 0-20 MHz.

Optional input filtering (-FT models) reduces reflected ripple noise and is similarly low and also fully specified for typical values (exact value depends on input voltage range). Typical RMS noise over a 10 kHz to 1 MHz bandwidth is specified for the input.

Full overload protection is provided by independent pulse-by-pulse current limiting or with the optional over-temperature shutdown circuit (-FT models). These protection features assure you that our HP triple will provide you with zero failure rate operation.

Five sided shielding is standard along with specified operation over the full industrial temperature range of -40 to +90° C case temperature.

Applying The Input

Figure 1 shows the recommended input connections for the HP Triple DC/DC converter. A fuse is recommended to protect the input circuit and should not be omitted. The fuse serves to prevent unlimited current from flowing in the case of a catastrophic system failure.

20 Watt HP Triple Series DC/DC Converters

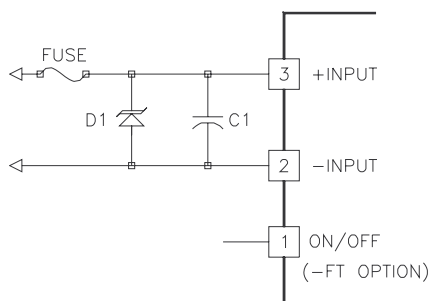

Figure 1.

Standard connections for the HP triple input. The ON/OFF pin may be left floating if it is not used (-FT option only). The input protection fuse should not be omitted. If desired, an external transient protection diode (D1) can be used at the input. See "Applying the input" for suggestions regarding C1. See the CALEX application notes for more information on fuses.

When using the standard model, be sure that the impedance at the input to the converter is less than 0.09 ohms at the switching frequency. If the converter is located more than about 1 inch from the input source an added capacitor may be required directly at the input pins for proper operation.

Suitable capacitors for use at the input of the converter are given at the end of this section.

-FT Filtered Input Option

The -FT or filtered input option has an internal LC filter that greatly reduces input reflected ripple current. This option is useful when the lowest noise or highest power density is required on your system.

With the filtered input option no external capacitance on the input is required for most applications, in fact it can degrade the converters performance. Extremely low ESR capacitors (< 0.5 ohms) should not be used at the input as this will cause peaking of the input filters transfer function and actually degrade the filters performance.

Any stray line inductance effects that cause ringing at the converters input pins can be damped adequately with a 10 to 100 μF / 100 V, low cost, 0.5 to 5 ohm ESR, aluminum electrolytic capacitor. Normal RF bypass capacitors in the 1000 pF to 0.01 μF range may be used without harm.

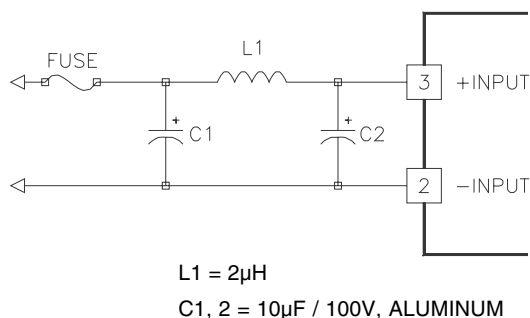

Figure 2.

This circuit may be used with the -FT option to reduce the reflected ripple current by approximately 30 dB. The filter must be built close to the converter for maximum effectiveness. All grounds should be routed directly to the -input pin.

Very Low Noise Input Circuit

Figure 2 shows a very low noise input circuit that may be used with the -FT option converters. This circuit will reduce the input reflected ripple current by approximately 30 dB over the standard -FT option filter.

Suggested Capacitor Sources

These capacitors may be used at the input of the standard model only, see the filtered Input option section for more information when using the filtered input converter.

Suitable capacitors can be acquired from the following sources:

United Chemi-Con	SXE, RXC, RZ and RZA Series Suggested Part: SXE100VB221M12.5X35LL 220 μF , 100V, 105°C Rated ESR=0.087 Ohms Allowable Ripple=1.04 A @ 105°C
Nichicon	PR and PF Suggested Part: UPR100102MPHRH 1000 μF , 100V, 105°C Rated ESR=0.047 Ohms Allowable Ripple=1.32 A @ 105°C
Panasonic	HFE Series Suggested Part: ECEA2AFE221L 220 μF , 100V, 105°C Rated ESR=0.089 Ohms Allowable Ripple=1.04 A @ 105°C

Remote ON/OFF Pin Option

The optional remote ON/OFF pin may be left floating if this function is not used. The equivalent input circuit for the ON/OFF pin is shown in figure 3. The best way to drive this pin is with an open collector/drain or relay contact. See our application note titled "Understanding the remote ON/OFF function" for more information about using the remote ON/OFF pin.

When the ON/OFF pin is pulled low with respect to the -Input, the converter is placed in a low power drain state. The ON/OFF pin turns the converter off while keeping the input bulk capacitor fully charged, this prevents the large inrush current spike that occurs when the +input pin is opened and closed.

The ON/OFF pin should never be pulled more that 0.3 volts below the -input or have a voltage of greater than +8 volts applied to it.

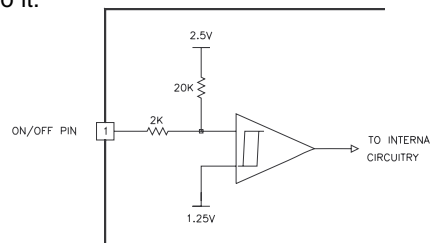

Figure 3.

The simplified schematic of the HP Triple series ON/OFF pin. The input impedance is approximately 20k ohms. By leaving this pin floating the converter will be in the ON state. When the pin is pulled below 0.7 volt (with respect to the -Input pin) the converter is placed in the power down or OFF state. See our application note on the remote ON/OFF function for more information.

20 Watt HP Triple Series DC/DC Converters

Applying The Output

Figure 4 shows typical output connections for the HP Triple. In most applications no external output capacitance will be necessary. Only your normal 1 to 10 μF tantalum and 0.001 to 0.1 μF ceramic bypass capacitors sprinkled around your circuit as needed locally are required. Do not add extra output capacitance and cost to your circuit "Just Because".

If you feel you must add external output capacitance, do not use the lowest ESR, biggest value capacitor that you can find! This can only lead to reduced system performance or oscillation. See our application note "Understanding Output Impedance For Optimum Decoupling" for more information.

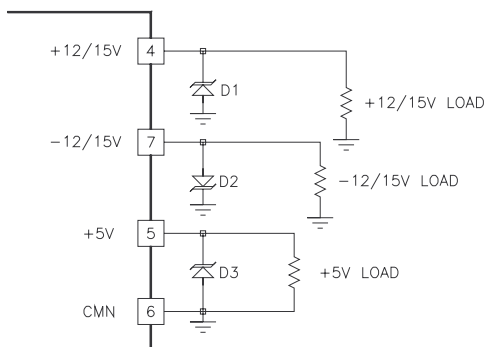

Figure 4.

The HP triple should be connected to your load as shown. All of the ground return currents should be returned directly to CMN pin. If desired, external transient protection diodes can be used.

Ultra Low Noise Output Circuit

The circuit shown in figure 5 can be used to reduce the output noise to below 10 mV P-P over a 20 MHz bandwidth. Size inductor L1 appropriately for the maximum expected load current. All of the ground connections must be as short as possible back to the CMN pin. The filter should be placed as close to the HP triple as possible, even if your load is at some distance from the converter.

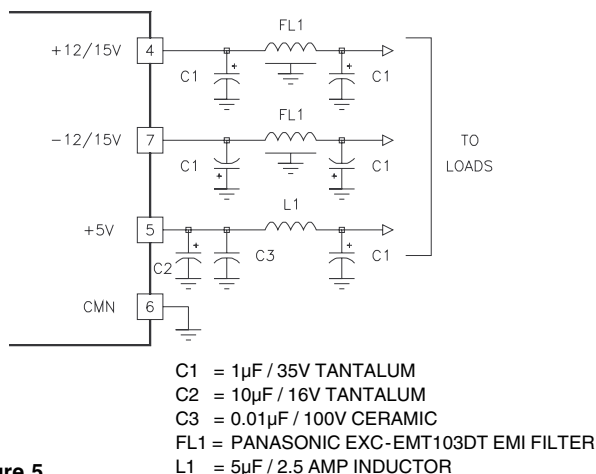

Figure 5.

For very low output noise applications this circuit will reduce the output noise to less than 10 mV P-P over a 0-20 MHz bandwidth. Be sure to size L1 appropriately for the maximum expected load current on the 5 volt output.

Operation With Very Light Loads

The HP Triple uses a technique called "Magnetically Coupled Cross Regulation" to provide the best regulation available with a single PWM regulator circuit. This scheme works very well when all loads are operated within 25% to 100% of their rated load range. When the loads become very unbalanced (i.e. one or more outputs at no load and the others at full load) the PWM can have difficulty trying to determine the best output voltage. The best situation is to keep the minimum load at 25% for each output and avoid operating any output unloaded.

The regulation of the HP triple may be improved by using dummy load resistors to keep the static output power above about 2 watts (check the exact value required by your circuit). The load may be balanced by adding a dummy load on the most lightly loaded outputs, the exact value will depend on your exact circuit requirements. This minimum load should not be required to be greater than 25% of each outputs full load value for quite good regulation.

Dynamic response of the HP triple will degrade when the unit is operated with less than 25% of full rated power.

If large load excursions or operation with very large load unbalances are required then a "Dual Loop" converter such as the CALEX XC triple may provide better performance in your circuit.

Thermal Overload Protection Option

The -FT option provides a thermal overload circuit that will protect the converter against overtemperature faults. The thermal overload circuit works by shutting the PWM circuit OFF when the case temperature exceeds about 105° C. When the case cools the converter will automatically restart.

The thermal overload circuit will prevent the converter from being damaged under the following conditions,

- Operation at abnormally high ambient temperatures.
- Most long term short circuit conditions.

This option is useful in applications that require the utmost reliability in unattended operation or where cooling system failures must not cause permanent damage.

Grounding

The input and output sections are fully floating from each other. They may be operated fully floating or with a common ground. If the input and output sections are connected either directly at the converter or at some remote location from the converter it is suggested that a 3.3 to 10 μF , 0.5 to 5 ohm ESR capacitor bypass be used directly at the converters output pins. These capacitors prevent any common mode switching currents from showing up at the converters output as normal mode output noise. See "Applying the Output" for more information on selecting output capacitors.

Also see the CALEX application note "Dealing With Common Mode Noise" for more information on using common grounds.

20 Watt HP Triple Series DC/DC Converters

Case Grounding

The copper case serves not only as a heat sink but also as a EMI shield. The 0.017 inch thick case provides >25 dB of absorption loss to both electric and magnetic fields at 220 kHz, while at the same time providing 20 to 40 % better heat sinking over competitive thin steel, aluminum or plastic designs.

The case shield is tied to the -input pin. This connection is shown on the block diagram. The case is floating from the output sections. The input is coupled to the outputs only by the low 400 pF of isolation capacitance. This low I/O capacitance insures that any AC common mode noise on the inputs is not coupled to your output circuits.

Compare this isolation to the more usual 1000 - 2000 pF found on competitive designs and you will see that CALEX provides the very best DC and AC isolation available. After all, you are buying an isolated DC/DC to cut ground loops. Don't let the isolation capacitance add them back in.

Temperature Derating

The HP Triple series can operate up to 90°C case temperature without derating. Case temperature may be roughly calculated from ambient by knowing that the HP Triples case temperature rise is approximately 9.5°C per package watt dissipated.

For example: If a 24T HP converter is outputting 15 watts, at what ambient could it expect to run with no moving air and no extra heatsinking?

Efficiency of a 24T is approximately 84% at 15 watts of output power, this leads to an input power of about 18 watts. The case temperature rise would be 18 - 15 watts or 3 watts \times 9.5 = 29°C. This number is subtracted from the maximum case temperature of 90°C to get: 61°C.

This example calculation is for an HP triple without any extra heat sinking or appreciable air flow. Both of these factors can greatly affect the maximum ambient temperature (see below). Exact efficiency depends on input line and load conditions, check the efficiency curves for exact information.

This is a rough approximation to the maximum ambient temperature. Because of the difficulty of defining ambient temperature and the possibility that the loads dissipation may actually increase the local ambient temperature significantly, these calculations should be verified by actual measurement before committing to a production design.

Remember, it is the users responsibility to be sure that the case temperature of the HP Triple does not exceed 90°C for maximum reliability in operation.

Typical Performance (Tc=25°C, Vin=Nom VDC, Rated Load).

