

48S121.750BCE 750 Watt

48/12V Bi-Directional DC/DC Converter



Product Overview

The 750-Watt 48S12.750BCE bi-directional non-isolated DC/DC converter provides a complete solution for in-vehicle power distribution with 12V/48V battery configurations for a variety of applications including micro and mild hybrid automotive systems. The bi-directional DC/DC converter charges a low side (12V) battery during normal operation (buck mode) and charges or assists the high voltage (48V) battery in emergency situations (boost mode).

The bi-directional DC/DC converter operates more as an ideal current source with variable direction, thus allowing energy transfer between two voltage domains. Voltage feedback maintains the output voltage within the acceptable operating range and eventually allows a custom charging profile for the battery pack.

Features

- Automotive 12V/48V battery system
- Buck and Boost modes of operation
- Low Side (LS): 12V Input Voltage Range: 6V to 16V
- High Side (HS): 48V Input Voltage Range: 32V to 63.2V
- Overcurrent, Overvoltage, and Over-temperature Protection. All protections are latching.
- Disconnect switch LS (12V) and HS (48V)
- Reverse polarity protection
- Constant Voltage and Constant Current Mode
- Average Current Mode Control
- Internal Temperature Monitoring
- High-power density
- Efficiency up to 96.7%
- Dimensions 4.84" x 6.97" x 1.75" (123 x 177 x 44.5 mm)
- Weight 3.04 lbs. (1.38 Kg)
- Excellent thermal performance
- Constant switching frequency
- CAN 2.0b Interface including remote ON/OFF
- Good shock and vibration damping
- IP67 with mating connectors installed

Operational Characteristics

Parameter	Min.	Typ.	Max.	Units
Operating Ambient Temperature			75	°C
Storage Temperature	-55		125	°C

BUCK MODE

Parameter	Min.	Typ.	Max.	Units
Input Voltage		48		V
Operating Voltage Range	32		63.2	V
Turn-on Threshold		32		V
Turn-off Threshold		30		V
Over-Voltage Protection		66		V
Efficiency, full load – 750W		96.7		%

BOOST MODE

Parameter	Min.	Typ.	Max.	Units
Input Voltage		13.8		V
Operating Voltage Range	9		16	Vdc
Turn-on Threshold		9		Vdc
Turn-off Threshold		8		Vdc
Efficiency, full load – 750W		95.8		%

NOTE:

This product as designed is not intended for use in Power-train applications. This product was not designed in compliance to IOS-26262. Contact your local sales representative for application-specific design requests.

Mechanical Specifications

Weight		3.04	lbs.
		1.38	kg
Case Dimension	Not including connectors	4.84 x 6.97 x 1.75	inches
		123 x 177 x 44.5	mm
	Including connectors	5.57 x 6.97 x 1.75	inches
		141.5 x 177 x 44.5	mm
Cover	Material	.031" [0.8mm] THK Steel	
	Finish	Brushed	
Mounting Hardware	Fastener	M6 or 1/4-20 screw	
	Torque	15	Nm

OUTLINE DRAWING

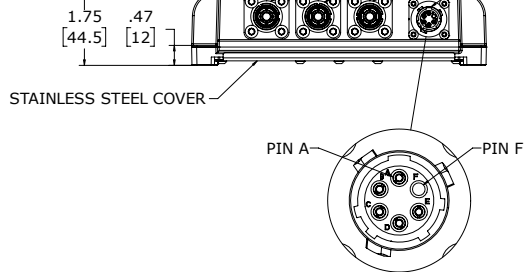
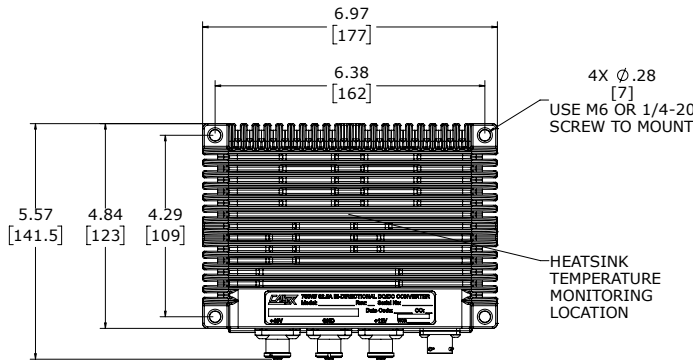

DETAIL A
SCALE 4 : 1

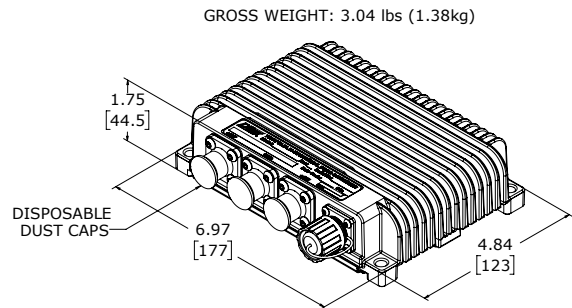

ISOMETRIC VIEW (REFERENCE)

Ref.	Function	Connector	Mates with
+HS	+48V	Amphenol C10-764863-2003	Amphenol SLP(I)PA16BSR3
GND	GND	Amphenol C10-764863-1000	Amphenol SLP(I)PA16BSB0
+LS	+12V	Amphenol C10-764863-2001	Amphenol SLP(I)PA16BSR1
PIN A	CAN-L	Amphenol RTS010N6S03	Amphenol RTS6BS10N6P03
PIN B	CAN-H		
PIN C	ON/OFF		
PIN D	GND		
PIN E	POWER		
PIN F	UNUSED		

NOTE: Unless otherwise specified, all dimensions are in inches. Tolerances: x.xx in. ±0.02 in.