

HBC800 Series

E-Mobility 4kW DC/DC Isolated Bidirectional Power Converter Module



Product Overview

HBC800 is a series of rugged, highly efficient, 4kW liquid-cooled, bidirectional DC/DC power converters that convert 440-875V high side DC input voltage into a 12Vdc or 24Vdc isolated low side voltage, supporting 12/24V battery configurations.

HBC800 power converters incorporate a digitally controlled Dual Active Bridge topology with synchronous output rectification to achieve high efficiency and EMI performance. The compact thermally optimized IP67 ingress rated enclosure provides a high degree of shock and vibration resistance, suitable for deployment within harsh environments.

Bi-directional conversion capability:

- **Buck-Mode Direction:** Converts the high side input voltage (440-875Vdc) into a 12V/24V low side output.
- **Boost-Mode Direction:** Converts low side input of 12V/24V into the high side output voltage (440-875Vdc).

The comprehensive SAE J1939 compliant CAN digital interface, standard hardware signals including HVIL (High Voltage Interlock Loop) and the bi-directional conversion features make this series suitable for adaptation in industrial, agriculture, marine, mining and other E-mobility applications.

Features

- Bidirectional operation
- Wide high-side Input Voltage range: 440V to 875Vdc via robust Amphenol Powerlok series connector with integrated HVIL contacts
- 12Vdc and 24Vdc models, supporting 12/24V battery configurations
- CAN 2.0B SAE J1939 compliant digital communications interface for monitoring, control and configuration capability
- High efficiency; up to 96 percent
- Input to output safety isolation
- Liquid cooled, IP67 rugged enclosure: 359 (L) x 205 (W) x 78 (H) suitable in harsh environments
- Over-Current, Short-Circuit, and Over-Temperature fault protection
- E-Mark Pending

OPERATIONAL CHARACTERISTICS

PARAMETER	MIN	TYP	MAX	UNITS
Operating Temperature	-40		+85	°C
Storage Temperature	-40		+95	°C

BUCK MODE

Parameter	Min.	Typ.	Max.	Units
Input Voltage Range	440	700	875	Vdc
Input Voltage Range at 100% Load	620		780	Vdc
Turn-on Voltage	430		440	Vdc
Turn-off Voltage	400	410	420	Vdc
Input Current			6	Adc
Input Over-Voltage Protection	885		900	Vdc
Efficiency	96			%

BOOST MODE

Parameter	Min.	Typ.	Max.	Units
Input Voltage Range	9	14	16	Vdc
Input Voltage Range at 100% Load	12		16	Vdc
Turn-on Voltage	8		9	Vdc
Turn-off Voltage	8		9	Vdc
Efficiency	96			%

ORDERING GUIDE

Model	Input Voltage	Output Voltage	Output Current	Max. Output
800S12.4KOHBC	440-875Vdc	9-16Vdc	300A	4kW
800S24.4KOHBC		16-32Vdc	150A	

Mechanical Specification

MECHANICAL	DESCRIPTION	UNIT
Dimensions	359 (L) x 205 (W) x 78 (H)	mm
Weight	6	kg
Enclosure	Aluminum, anodized IP67	

OUTLINE DRAWING

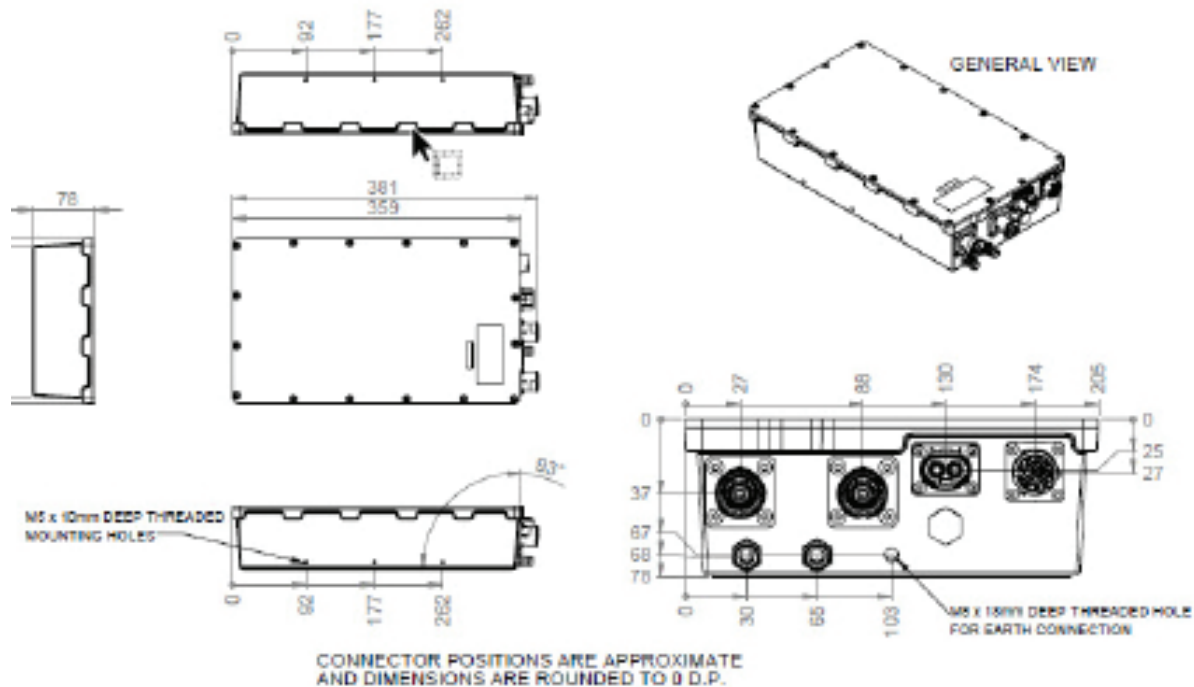

MECHANICAL NOTES:

- THIS DRAWING IS A GRAPHICAL REPRESENTATION OF THE POWER MODULE SHOWN FOR ILLUSTRATION PURPOSED. NOT ALL FINE DETAILS ARE SHOWN. PLEASE CONTACT CALEX FOR 3D MODEL OR F COMPONENT DRAWINGS FOR DETAILED DIMENSIONS AND MATERIAL INFORMATION
- REFERENCE FILE: 210614_DRG1143-1A DC DC CONVERTER ASSEMBLY
- DIMENSIONS: MM, MATERIAL: 0.80MM HOT DIPPED GALVANIZED STEEL, GRADE G60 MINIMUM SPANGLE FINISHED WITH A CR(6+) FREE CORROSION RESISTANT COATING
- DIMENSIONS OF CONNECTOR LOCATIONS SHOWN TO CENTRE OF CONNECTORS
- HOSE TAILS FOR COOLING CIRCUIT TO FIT 12MM INNER DIAMETER HOSE FOR BOTH INLET AND OUTLET FLOW
- CONNECTOR LOCATIONS ARE APPROXIMATE
- DIMENSIONS ARE ROUNDED TO 0 DP